



RBV07 Swivel Inflator Range Maintenance Manual

Version 0.95
April 2019
Written by Tino de Rijk

Table of Contents

1. Introduction	4
1.1 Functional description	4
1.2 Servicing	4
1.3 Warranty.....	4
1.4 Copyright and Applicable Law.....	4
3. RBV07 Swivel Inflator Range Exploded Diagrams and Parts Lists	5
3.1 RBV07(A) Single Swivel Inflator main assembly	5
3.2 RBV07(A)/DUAL Dual Swivel Inflator main assembly	6
3.3 RBV07(A)/SO Single Swivel Inflator with Shutoff Valve main assembly	7
3.4 RBV07(A)/DUAL/SO Dual Swivel Inflator with Shutoff Valve main assembly	8
3. General Information	9
3.1 Four versions	9
3.2 Gas flow paths	9
3.3 Single Swivel Inflators - RBV07 & RBV07A.....	9
3.4 Dual Swivel Inflators - RBV07/DUAL & RBV07A/DUAL	10
3.5 Single Swivel Inflators with Flowstop Shutoff - RBV07/SO & RBV07A/SO ..	11
3.6 Dual Swivel Inflators with Shutoff - RBV07/DUAL/SO & RBV07A/DUAL/SO	12
3.7 Recommended Position of the Collar of the GC3 Flowstop	13
4. Service Kit Contents and Tools	14
4.1 Service Kit Contents.....	14
4.2 Tools Needed.....	15
5. Disassembly Instructions	16
5.1 General overview: main disassembly steps	16
5.2 Unscrew the 5/16" inflator stem(s) from the inflator body.....	16
5.3 Unscrew the GC3 Flowstop isolator from the 5/16"-9/16" adapter	17
5.4 Unscrew the 5/16"-9/16" adapter(s) from the outlet body or inflator body	18
5.5 Remove the inflator body from the outlet body.....	19
5.6 Unscrew the blue or green push button from the inflator spindle	21
5.7 Remove the O-ring from the inflator body	23
5.8 Remove low profile counterlung inlet elbow from counterlung	26
5.9 Remove O-rings from MP counterlung inflator hose.....	27
5.10 When GC3 Flowstop is fitted: remove O-rings from both ends of MP hose	27
AP50 Medium Pressure (MP) hose disassembly	28
5.11 Remove circlip from snap connector body	28
5.12 Remove sliding collar from snap connector body.....	28
5.13 Remove spring from snap connector body.....	28
5.14 Remove 4 ball bearings from snap connector body	29
5.15 Unscrew Schraeder valve from snap connector body	29
5.16 Remove O-ring from snap connector body.....	30
6. Clean and Replace Service Parts.....	31
6.1 Ultrasonically clean deposits from all metal parts.....	33
6.2 Replace all O-rings with new ones from the Service Kit.....	34
6.3 How to lightly grease O-rings	34
7. Assembly Instructions	36
7.1 General overview: main assembly steps.....	36

7.2 Place a new O-ring into the inflator body.....	36
7.3 Screw the blue or green push button onto the inflator spindle.....	37
7.4 Fit a new O-ring onto the inflator body and locking ring	39
7.5 Connect the inflator body to the outlet body	40
7.6 Screw the 5/16"-9/16" adapter(s) back into the outlet body or inflator body .	41
7.7 Screw the GC3 Flowstop isolator back into the 5/16"-9/16" adapter	43
7.8 Screw the 5/16" inflator stem(s) back into the inflator body.....	43
7.9 Fit new O-rings to MP counterlung inflator hose	44
7.10 Fit low profile counterlung inlet elbow back onto counterlung	45
7.11 When a GC3 Flowstop is fitted: fit new O-rings to both ends of MP hose ..	46
7.12 Place the yellow locking strap back onto the GC3 isolator.....	47
AP50 hose assembly	47
7.13 Fit new O-ring inside snap connector body	47
7.14 Screw new Schraeder valve into snap connector body	48
7.15 Push 4 ball bearings back into snap connector body	48
7.16 Put spring onto snap connector body	48
7.17 Push sliding collar onto snap connector body	49
7.18 Refit circlip onto snap connector body.....	49
8. Testing Instructions.....	50
8.1 Test for leaks and proper operation.....	50

1. Introduction

1.1 Functional description

The AP RBV07 Swivel inflator range is a series of breathing gas inflators designed for use with any AP Inspiration rebreather fitted with back-mounted counterlungs. Their unique property is the swivel design with rotating inlet ports - which make it easy for the diver to plug in various breathing gasses before and/or during the dive.

1.2 Servicing

Before servicing these swivel inflators, you must receive instruction and certification in the maintenance of these inflators by AP Diving Ltd.

Without the correct training it is possible to service and configure the RBV07 Swivel inflators incorrectly in an unsafe manner. Factory or Dealer prescribed service for these inflators is recommended at least once annually.

The Inspiration, Evolution and Evolution+ closed circuit rebreathers' CE certification to EN14143 is unaffected by the fitting of this RBV07 Swivel inflators.

The RBV07 swivel inflators meet the requirements of the Personal Protective Equipment Directive 89/686/EEC – CE certification when fitted to an AP Diving rebreather.

 **WARNING:** When servicing the RBV07 swivel inflators it is VERY important that all parts that may suffer wear and tear get replaced. It is also very important that the correct tools are used to avoid damaging any part of the inflator in the disassembly and assembly process. Please don't try to save money by re-using parts that really should be replaced during a proper servicing action.

 The numbers between brackets after the part names in the disassembly and assembly chapters correspond to the sequence numbers in the diagrams in chapter 2.

1.3 Warranty

The RBV07 Swivel inflators are covered by an AP 2 year warranty against defects in materials or workmanship. This warranty is only offered to the original purchaser and is not transferable. A copy of the receipt must be presented whenever obtaining warranty service.

1.4 Copyright and Applicable Law

This Maintenance Manual is copyrighted, all rights reserved. It may not, in whole or in part, be copied, photocopied, reproduced, translated, or reduced to any electronic medium (including the Internet) or machine-readable form without prior consent in writing from AP Diving Ltd.

All products are sold on the strict understanding that only English Law applies in cases of warranty claims and product liability, regardless of where the equipment is purchased or used. Should a claim be made then the venue for this would be in Truro, England.

© 2019 AP Diving Ltd.
RBV07 Swivel Inflator Range Maintenance Manual

3. RBV07 Swivel Inflator Range Exploded Diagrams and Parts Lists

3.1 RBV07(A) Single Swivel Inflator main assembly

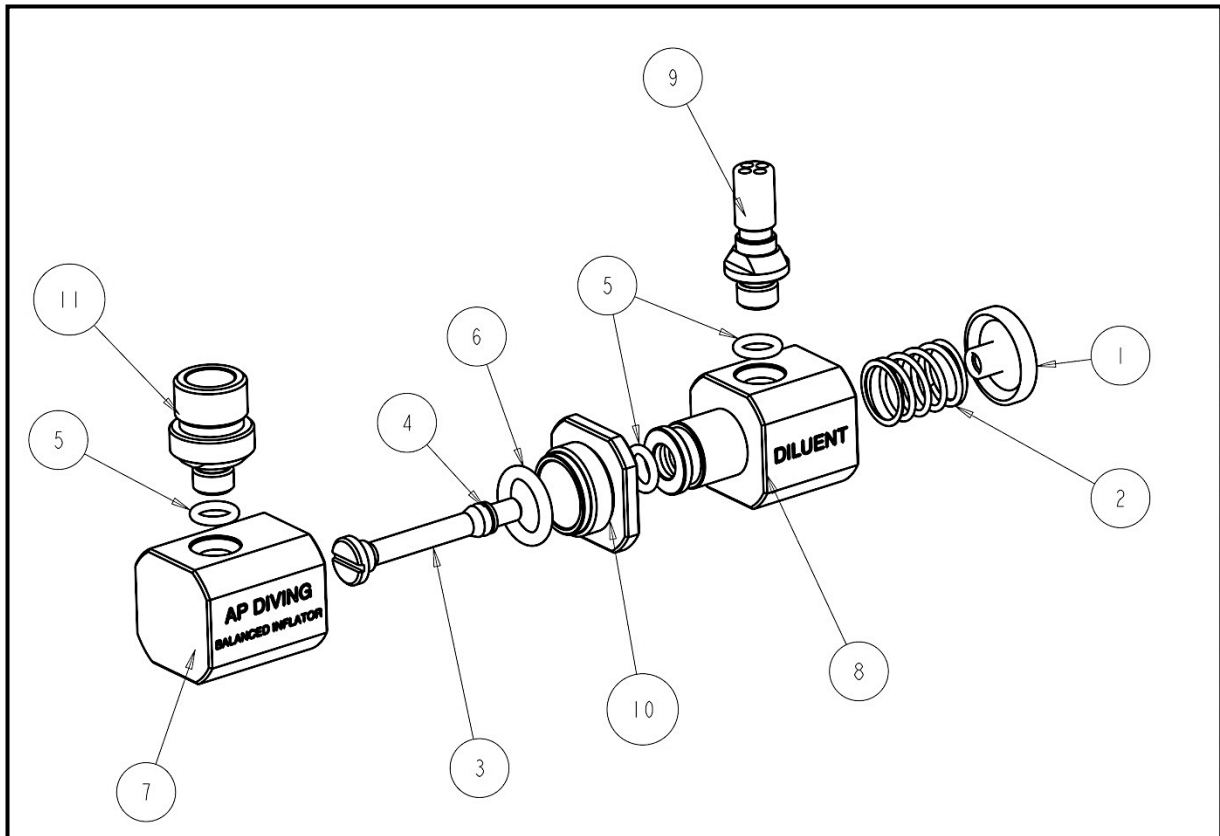

NUMBER	DESCRIPTION	PART NUMBER	QUANTITY
1	Push Button (Green or Blue)	AP_43	1
2	Spring	AP_43_A	1
3	Inflator Spindle	AP_52_C	1
4	BS-006-N70 O-ring	BS_006_N70	1
5	BS-010-N70 O-ring	BS_010_N70	3
6	BS-111-N70 O-ring	BS_111_N70	1
7	Single Outlet Body	RBV_07_01	1
8	Inflator Body	RBV_07_02	1
9	5/16" Inflator Stem	RBV_07_03	1
10	Locking Nut	RBV_07_04	1
11	5/16" – 9/16" Adapter	RBV_07_08	1

NOTE:

- RBV07 is the Diluent version, with blue push buttons and "DILUENT" engraving
- RBV07A is the Oxygen version, with green pushbuttons and "OXYGEN" engraving

3.2 RBV07(A)/DUAL Dual Swivel Inflator main assembly

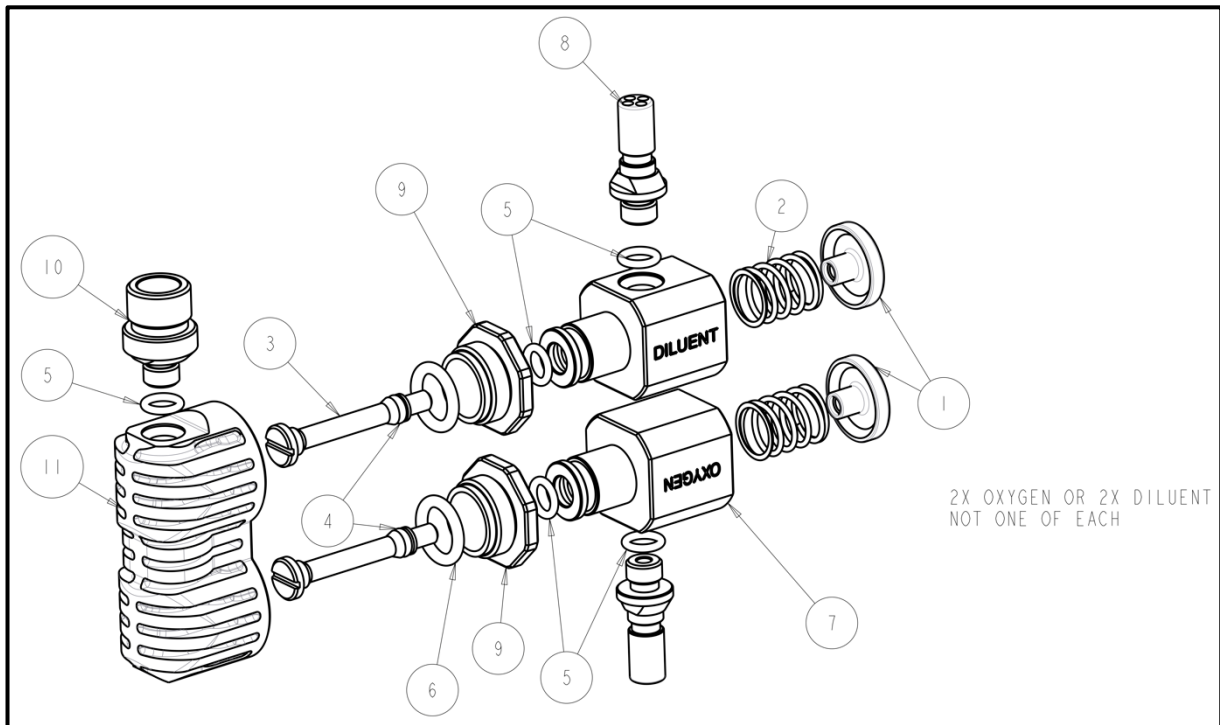

<u>NUMBER</u>	<u>DESCRIPTION</u>	<u>PART NUMBER</u>	<u>QUANTITY</u>
1	Push Button (Green or Blue)	AP_43	2
2	Spring	AP_43_A	2
3	Inflator Spindle	AP_52_C	2
4	BS-006-N70 O-ring	BS_006_N70	2
5	BS-010-N70 O-ring	BS_010_N70	5
6	BS-111-N70 O-ring	BS_111_N70	2
7	Inflator Body	RBV_07_02	2
8	5/16" Inflator Stem	RBV_07_03	2
9	8 Edge Locking Nut	RBV_07_04_8	2
10	5/16" – 9/16" Adapter	RBV_07_08	1
11	Dual Outlet Body	RBV_07_09	1

NOTE:

- RBV07/DUAL is the Diluent version, with blue push buttons and "DILUENT" engraving
- RBV07A/DUAL is the Oxygen version, with green pushbuttons and "OXYGEN" engraving

3.3 RBV07(A)/SO Single Swivel Inflator with Shutoff Valve main assembly

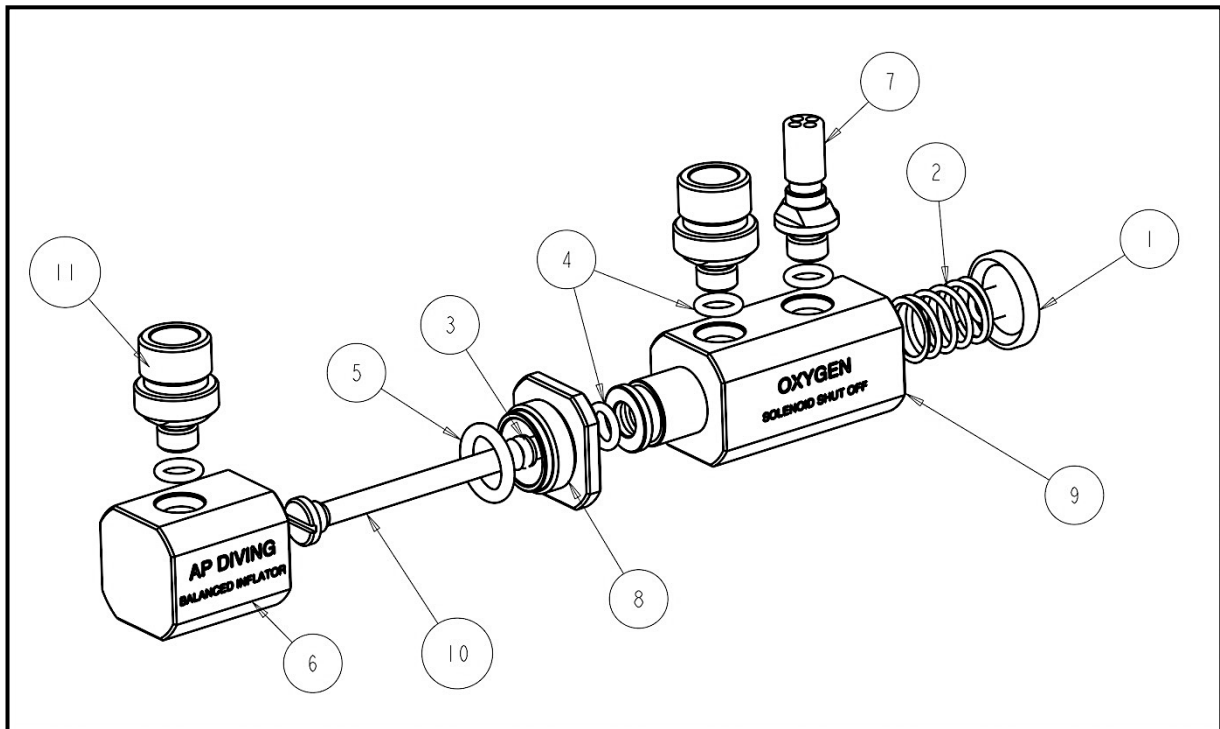

<u>NUMBER</u>	<u>DESCRIPTION</u>	<u>PART NUMBER</u>	<u>QUANTITY</u>
1	Push Button (Green or Blue)	AP_43	1
2	Spring	AP_43_A	1
3	BS-006-N70 O-ring	BS_006_N70	1
4	BS-010-N70 O-ring	BS_010_N70	4
5	BS-111-N70 O-ring	BS_111_N70	1
6	Single Outlet Body	RBV_07_01	1
7	5/16" Inflator Stem	RBV_07_03	1
8	Locking Nut	RBV_07_04	1
9	Shutoff Inflator Body	RBV_07_05	1
10	Shutoff Inflator Spindle	RBV_07_07	1
11	5/16" – 9/16" Adapter	RBV_07_08	2

NOTE:

- RBV07/SO is the Diluent version, with blue push buttons and "DILUENT" engraving
- RBV07A/SO is the Oxygen version, with green pushbuttons and "OXYGEN" engraving

3.4 RBV07(A)/DUAL/SO Dual Swivel Inflator with Shutoff Valve main assembly

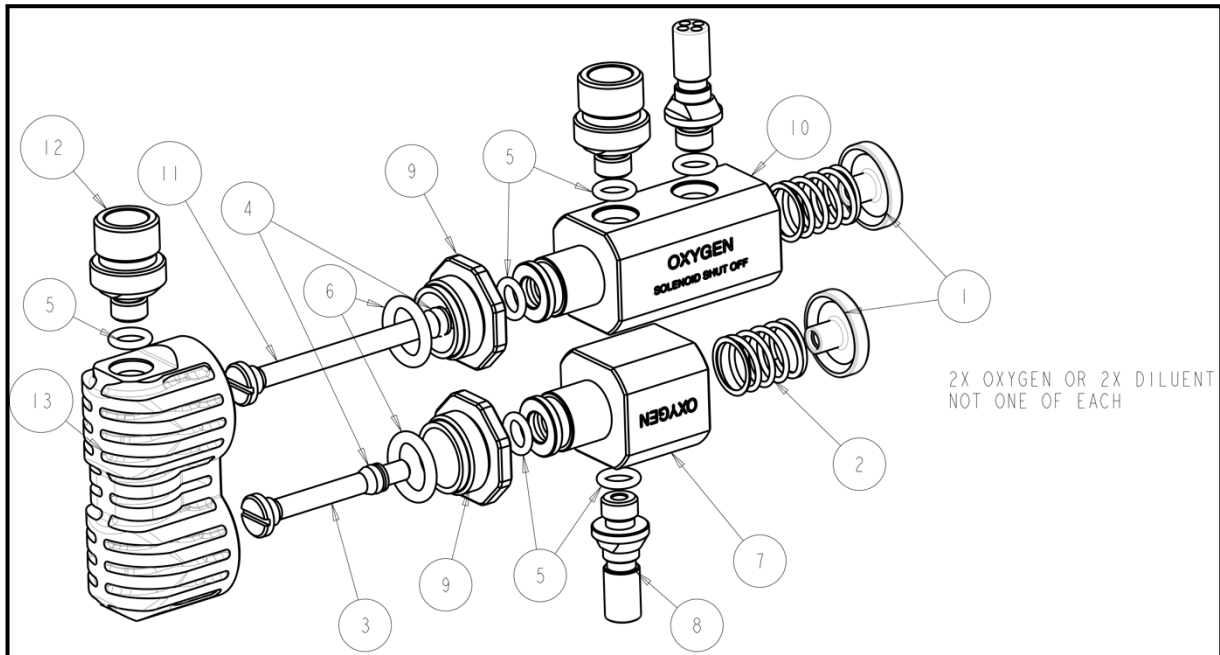

NUMBER	DESCRIPTION	PART NUMBER	QUANTITY
1	Push Button (Green or Blue)	AP_43	2
2	Spring	AP_43_A	2
3	Inflator Spindle	AP_52_C	1
4	BS-006-N70 O-ring	BS_006_N70	2
5	BS-010-N70 O-ring	BS_010_N70	6
6	BS-111-N70 O-ring	BS_111_N70	2
7	Inflator Body	RBV_07_02	1
8	5/16" Inflator Stem	RBV_07_03	2
9	8 Edge Locking Nut	RBV_07_04_8	2
10	Shutoff Inflator Body	RBV_07_05	1
11	Shutoff Inflator Spindle	RBV_07_07	1
12	5/16" – 9/16" Adapter	RBV_07_08	2
13	Dual Outlet Body	RBV_07_09	1

NOTE:

- RBV07/DUAL/SO is the Diluent version, with blue push buttons and "DILUENT" engraving
- RBV07A/DUAL/SO is the Oxygen version, with green pushbuttons and "OXYGEN" engraving

3. General Information

3.1 Four versions

There are four versions of the RBV07 Swivel inflator within the range. All four versions are available in both a Diluent as well as an Oxygen model, making a total of eight different models.

Note: The oxygen models have the letter "A" as a suffix in their part code.

3.2 Gas flow paths

In the pictures below (sections 3.3 to 3.6) the dotted arrows indicate the gas flow through the inflator when the push button is operated. These are "on-demand" gas flow paths which are normally blocked but can be temporarily opened by pushing the green or blue push button.

In the case of the four Swivel Inflator models with Flowstop shutoff (sections 3.5 & 3.6) the solid arrows indicate a straight-through gas flow path through the inflator i.e. a continuous gas flow regardless of whether the push button is operated. The gas flows uninterrupted from the inlet through the inflator to the outlet to which the GC3 Flowstop is attached. The gas flow can of course still be blocked by means of the slider on the GC3 Flowstop.

3.3 Single Swivel Inflators - RBV07 & RBV07A

The **RBV07(A)** has one MP (Medium Pressure) inlet and one MP outlet.

The **RBV07(A)** allows the diver to connect either an onboard or an offboard gas source. This is made easy by virtue of the swivel design in which the inlet port section of the inflator can rotate through 360 degrees.

The gas flow path is "on demand", i.e. gas only flows through when the button is pushed.

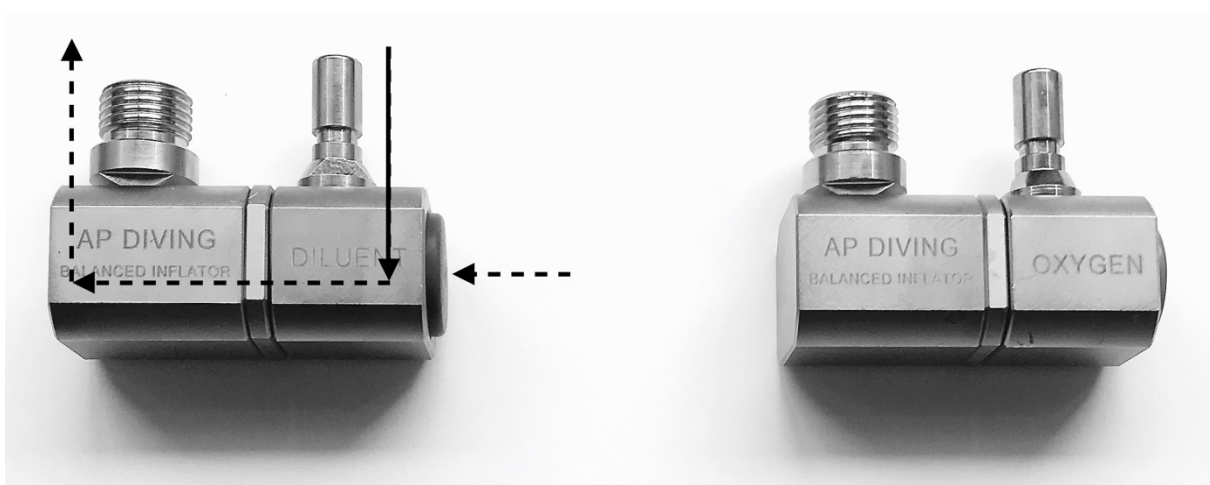

3.4 Dual Swivel Inflators - RBV07/DUAL & RBV07A/DUAL

The **RBV07(A)/DUAL** has two MP inlets and one MP outlet. Both inlets rotate to facilitate connection to wherever the gas sources are located.

The extra inlet (on the bottom in the picture below) allows the simultaneous connection of another gas source, either onboard or offboard. Each gas source can be operated by its own separate push button.

The gas flow paths are both "on demand", i.e. gas only flows when one of the buttons is pushed.

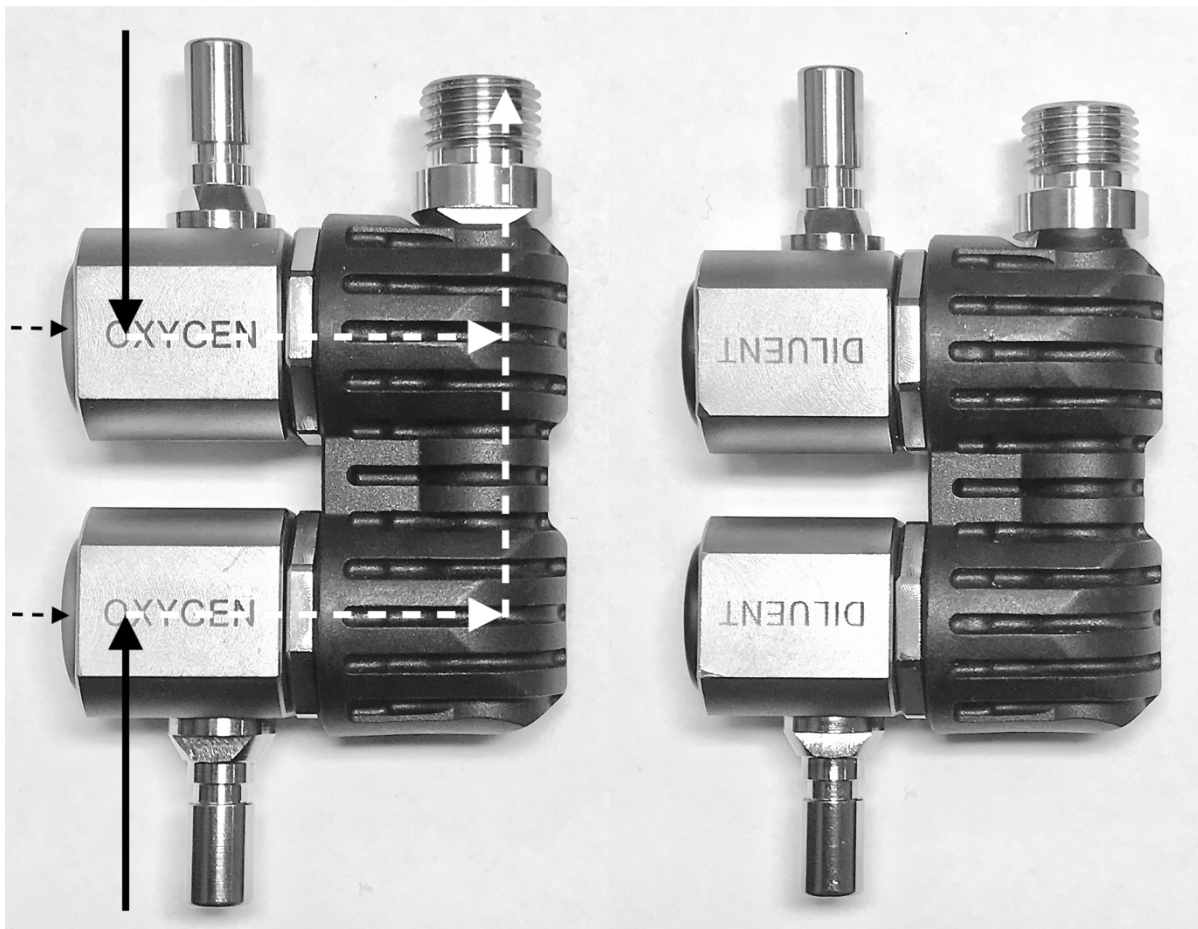

3.5 Single Swivel Inflators with Flowstop Shutoff - RBV07/SO & RBV07A/SO

The **RBV07(A)/SO** has one MP inlet and two MP outlets.

The central outlet is “straight-through”, which means the gas always flows from the inlet to this outlet regardless of the push button operation. This outlet is fitted with a GC3 Flowstop in-line gas isolator, which offers the option of shutting off the gas flow.

This outlet is typically connected to the solenoid (on the Oxygen model) or ADV (on the Diluent model). It gives the diver the option of blocking the gas flow to the solenoid or ADV in the unlikely event of a “solenoid stuck-open” or “ADV free-flow” fault situation or for any other reason the diver may want to isolate these gasses - for example, when performing a “diluent flush” cell check.

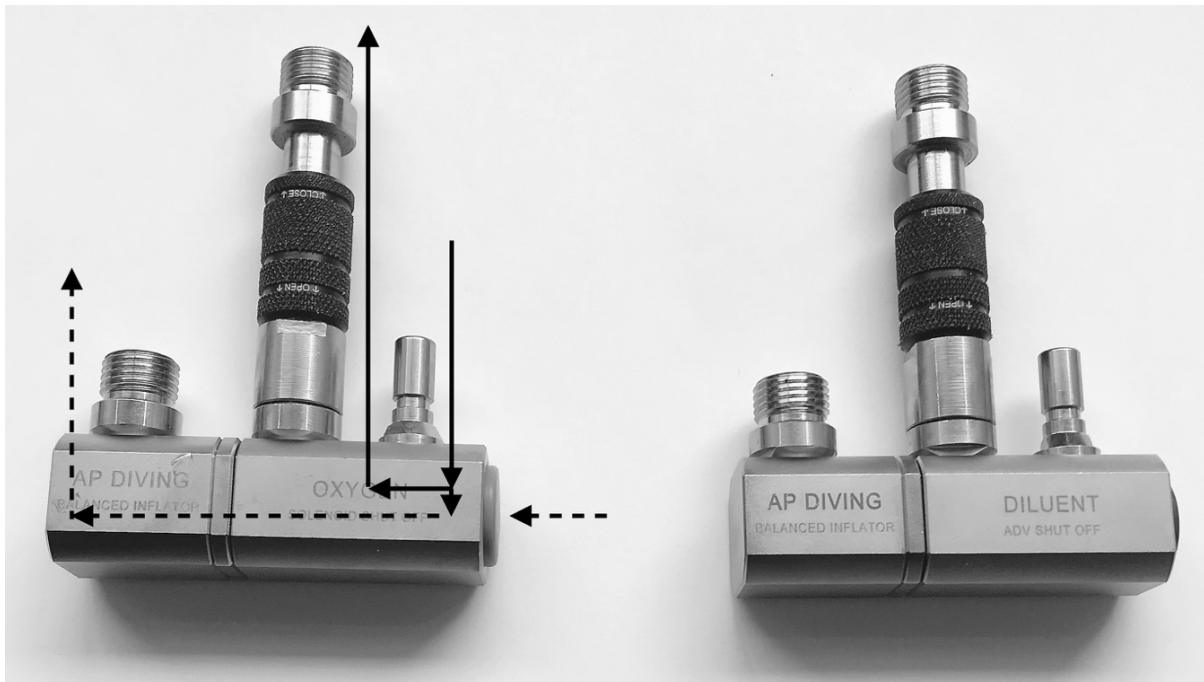

3.6 Dual Swivel Inflaters with Shutoff - RBV07/DUAL/SO & RBV07A/DUAL/SO

The **RBV07(A)/DUAL/SO** has two MP inlets and two MP outlets.

The central outlet is “straight-through”, which means the gas always flows from the inlet to this outlet regardless of the push button operation. This outlet is fitted with a GC3 Flowstop in-line gas isolator, which offers the option of shutting off the gas flow.

This outlet is typically connected to the solenoid (on the Oxygen model) or ADV (on the Diluent model). It gives the diver the option of blocking the gas flow to the solenoid or ADV in the unlikely event of a “solenoid stuck-open” or “ADV free-flow” fault situation or for any other reason the diver may want to isolate these gasses - for example, when performing a “diluent flush” cell check.

The extra inlet (on the bottom in the picture below) allows for the simultaneous connection of another gas source. The swivel design facilitates connection to wherever the gas source is located, onboard or off. It is operated by its own separate push button.

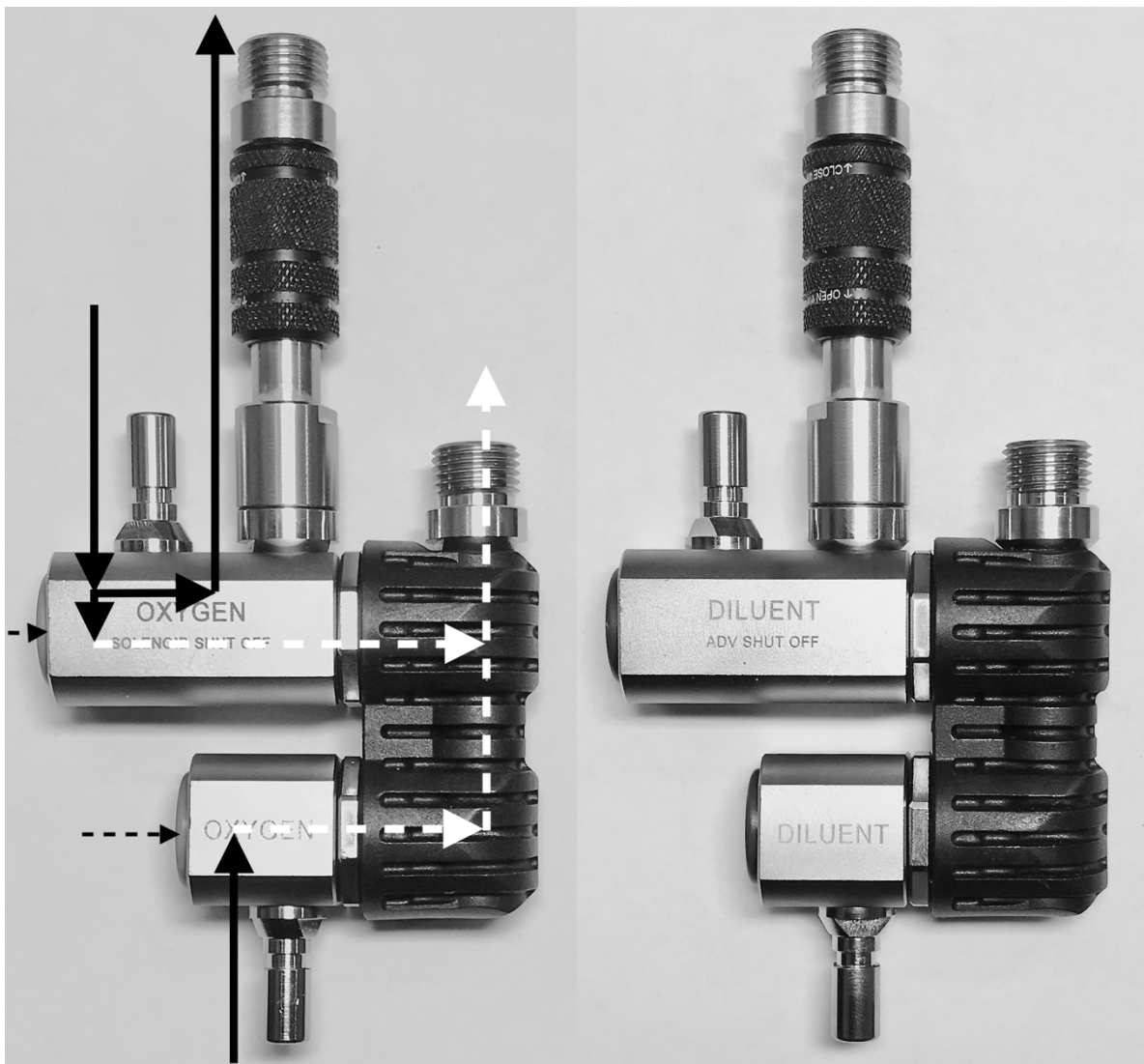

NOTE: The service procedure for the GC3 Flowstop in-line gas isolator as fitted to the RBV07(A)/SO and RBV07(A)/DUAL/SO is not described in this service manual. There is a separate manual available that fully describes the service procedure for this item.

3.7 Recommended Position of the Collar of the GC3 Flowstop

The GC3 Flowstop gas isolator features a knurled slider which functions to open or close off the gas flow. The orientation of this slider determines which slider direction is open and which is closed.

Although the orientation of the slider is reversible (by dis-assembly/re-assembly), APD **strongly** recommends that you stick to the position as it is delivered from the factory when fitted to the RBV07(A)/SO or RBV07(A)/DUAL/SO inflator.

From a safety and natural handling point-of-view this is the best position, for two reasons:

- 1) It makes closing the valve a positive *pull-up* action;
- 2) If the yellow locking strap gets accidentally dislodged, the valve “*fails-open*” in the open position rather than in the closed position. See also paragraph 7.8.

The recommended position of the collar is with the laser-engraved text “OPEN” text closest to the main body of the inflator, as show in the pictures below:



4. Service Kit Contents and Tools

4.1 Service Kit Contents

⚠ WARNING: When replacing O-rings, next to the size, the hardness of the O-rings (declared in degrees Shore, and indicated by the suffixes N70 and N90 in the parts lists in chapter 2) is ESSENTIAL for proper operation.

If, against our recommendation, you choose to select your O-rings to come from another source than AP Diving Ltd., make sure you select the right type in size AND hardness AND material (composition).

When servicing the RBV07 Swivel inflator, you can make use of a total of 10 AP Diving service kits:

- 4 for each diluent version of the inflator,
- 4 for each oxygen version of the inflator,
- 1 for the AP50 MP hose, and
- 1 for the GC3 Flowstop in-line gas isolator.
-

Note that there is a separate AP Diving maintenance manual for the GC3 Flowstop that also describes its service kit contents.

The contents of the various service kits are described in detail in chapter 6.

The order names for the service kits are as follows:

RBV07KIT	Single Diluent Swivel Inflator + outlet Hose + Counterlung Inlet Service Kit
RBV07AKIT	Single Oxygen Swivel Inflator + outlet Hose + Counterlung Inlet Service Kit
RBV07/DUAL/KIT	Dual Diluent Swivel Inflator + outlet Hose + Counterlung Inlet Service Kit
RBV07A/DUAL/KIT	Dual Oxygen Swivel Inflator + outlet Hose + Counterlung Inlet Service Kit
RBV07/SO/KIT	Single Diluent Swivel Inflator with Shutoff + outlet Hose + Counterlung Inlet + Flowstop outlet-Hose Service Kit
RBV07A/SO/KIT	Single Oxygen Swivel Inflator with Shutoff + outlet Hose + Counterlung Inlet + Flowstop outlet-Hose Service Kit
RBV07/DUAL/SO/KIT	Dual Diluent Swivel Inflator with Shutoff + outlet Hose + Counterlung Inlet + Flowstop outlet-Hose Service Kit
RBV07A/DUAL/SO/KIT	Dual Oxygen Swivel Inflator with Shutoff + outlet Hose + Counterlung Inlet + Flowstop outlet-Hose Service Kit
AP50KIT	AP50 snap connector Hose Service Kit
FLOWSTOP SERVICE KIT – GC3A	GC3 Flowstop In-line Gas Isolator Service Kit



4.2 Tools Needed

There are no special tools needed for servicing the RBV07 Swivel inflator.

Normal tools needed are:

- A 5mm Allen key
- 8, 12, 13, 14 and 24mm spanners
- A torque wrench for low torque settings (down to 4 Newton Meter)
- A screw driver
- a bench vice, fitted with soft jaws
- O-ring picking tools
- Oxygen-compatible grease
 - o see chapter 5 for remarks about when you need to keep this device in oxygen service
- (Access to) an ultrasonic bath for cleaning the metal parts.

 **WARNING:** Do NOT use aggressive chemicals. They might damage the metal plating of the RBV07 Swivel inflator. Use an ultrasonic cleaning bath with a suitable cleaning fluid. A very good cleaning fluid is Biox "O2" immersion fluid. See WWW.BIOXINT.COM for further information and distributors.

The use of rubber gloves while re-assembling the RBV07 Swivel inflator is recommended to avoid rendering the RBV07 Swivel inflator oxygen unclean due to human touch.

5. Disassembly Instructions

5.1 General overview: main disassembly steps

Despite the fact that all eight models of the RBV07 range of inflators have different layouts and functionality, the service procedures for these inflators have a lot in common. For that reason, the disassembly steps of the 8 different models are not described separately for each one, but are consolidated into steps that are common to all.

There are four main steps in the disassembly process:

1. Unscrew and remove all inlet and outlet adapters:
 - a. The 5/16" inflator stems,
 - b. The 5/16"-9/16" adapters and
 - c. The GC3 Flowstop isolators (where fitted).
2. Remove the swivelling inflator bodies (the parts with the blue or green buttons) from the outlet bodies by unscrewing the connecting locking nuts from the outlet bodies.
3. Remove the blue or green push buttons by unscrewing them from the inflator spindles, and subsequently pull out the inflator spindles.
4. Remove all O-rings and clean the metal parts.

5.2 Unscrew the 5/16" inflator stem(s) from the inflator body

- Use an 8 mm spanner to unscrew the inflator stem from the inflator body.
- Remove the O-ring and discard it.



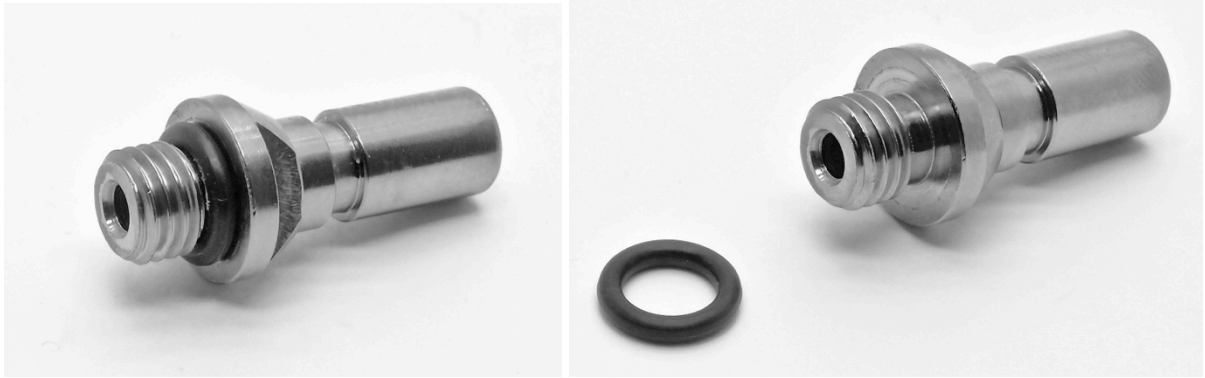

5.3 Unscrew the GC3 Flowstop isolator from the 5/16"-9/16" adapter

- **ATTENTION:** This step only applies to the RBV07(A)/SO and RBV07(A)/DUAL/SO versions of the inflator, which are fitted with a GC3 in-line gas isolator.
- Remove the yellow locking strap from the GC3 isolator.
- Use a 14 mm spanner to unscrew the GC3 Flowstop from its adapter.
- **NOTE:** the service procedure for the GC3 Flowstop gas isolator is described in a separate AP maintenance manual, available on the AP Diving website.



- If the adapter becomes unscrewed from the inflator body in the process: don't worry, as the adapter also needs to be unscrewed anyway. If this happens, use a 12 mm spanner and a 14 mm spanner to separate the GC3 and the adapter from each other.



5.4 Unscrew the 5/16"-9/16" adapter(s) from the outlet body or inflater body

- Use a 5 mm Allen key to unscrew the adapter from the single or dual outlet body or inflater body, counter-clockwise.
- Remove the O-ring from the adapter and discard it.



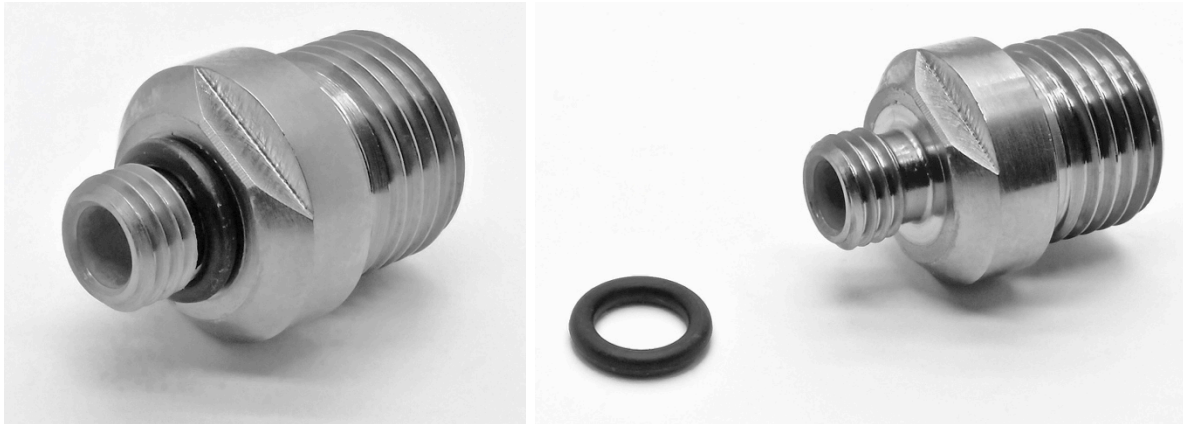

5.5 Remove the inflater body from the outlet body

- Use a permanent marker to place a small mark on both the locking ring and the outlet body. This serves to later on, during assembly, act as an indicator as to how far to screw the locking nut back into the outlet body.
- Clamp the outlet body into a bench vice.
ATTENTION: when using the vice, make sure to fit it with soft jaws (plastic or fibre). This avoids damaging the clamped inflater body and its nickel-plated coating.
- **ATTENTION:** when clamping the black synthetic dual outlet body into the vice, use as little force as possible to avoid distorting the dual outlet body.

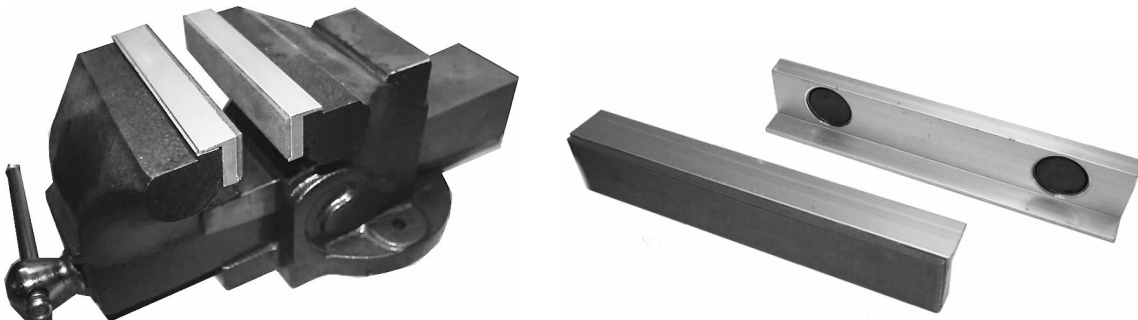

- Use a 24 mm spanner to unscrew the locking nut and inflater body counter-clockwise from the outlet body.
- **ATTENTION:** Make sure the jaw of the spanner ONLY touches the inflater body and the locking ring, i.e. the parts with "OXYGEN" or "DILUENT" laser engraving and containing the blue or green push button. The jaw of the spanner should **NOT** touch the outlet body.

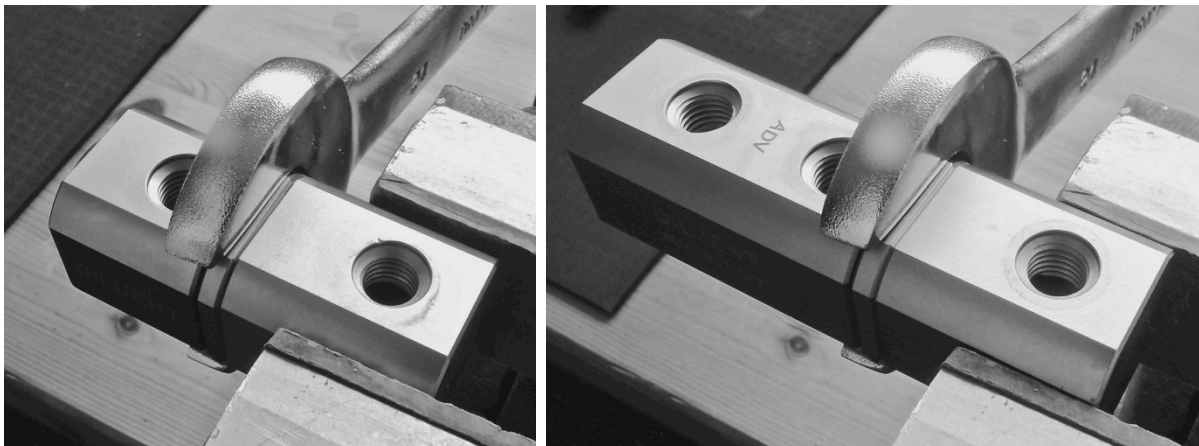

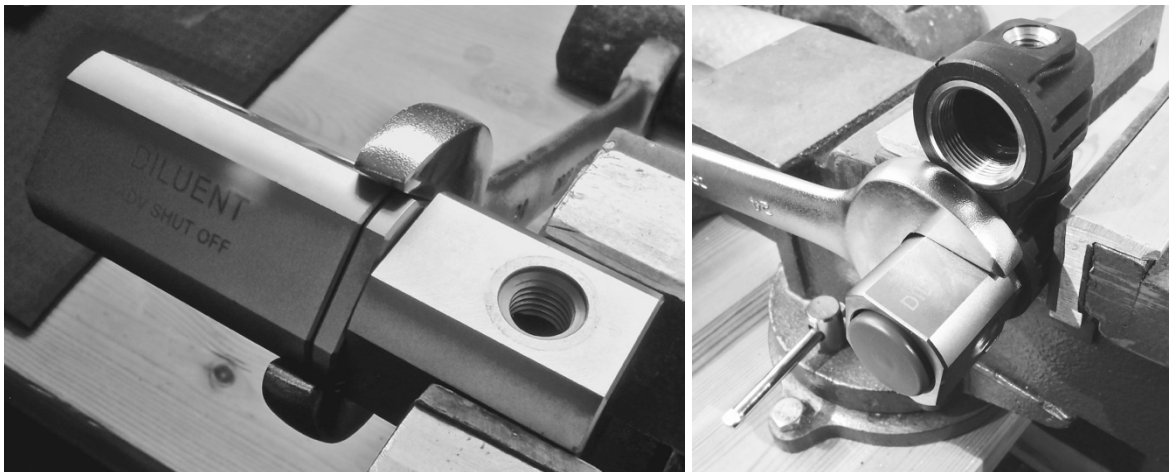

- Avoid the use of an adjustable spanner, as it might damage the coating of the inflater body and locking ring.
- Remove the large O-ring from the stem of the inflater body, discard it and subsequently lift the locking nut from the inflater body.





5.6 Unscrew the blue or green push button from the inflater spindle

- Use a non-slip surface that has sufficient gliding resistance, like a piece of rubber from a car or bike inner tube.
- Place the inflater body with the push button down onto this rubber surface. The aim of the rubber surface is to prevent rotation of the push button while unscrewing the inflater spindle from the push button.
- Push down on the inflater body, pushing the push button back into the inflater body against the spring pressure. This will cause the end of the inflater spindle to stick out of the inflater body.
- Use a screwdriver to unscrew the inflater spindle from the push button.



- **NOTE:** there is a small number of early RBV07s in the field that have inflater spindles without a groove. These spindles can be removed by pushing on the push button, so that the inflater spindle sticks out. The exposed spindle end can now be removed by using pliers. See picture below:

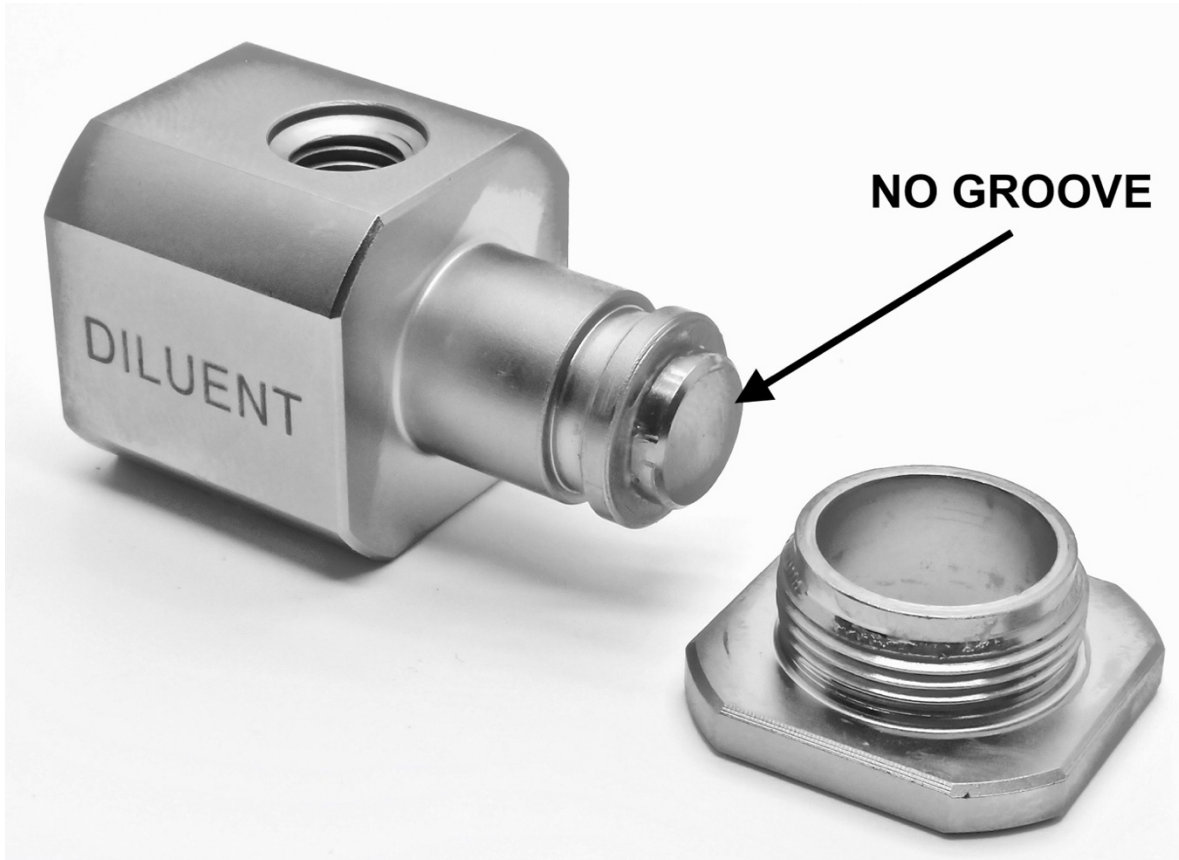

- Pull the inflater spindle out, remove its O-ring and discard it.
- Make sure not to lose the spring.
- Discard the blue or green push button.



- Remove the O-ring from the inflator spindle and discard it.



5.7 Remove the O-ring from the inflator body

- Use a dental pick or similar device to remove the O-ring from the inflator body.



This completes the disassembly of the inflator assembly with its inlet and outlet adapters.





5.8 Remove low profile counterlung inlet elbow from counterlung

- Unscrew (counter clockwise) the knurled locking ring that holds the low profile counterlung inlet elbow attached to the inlet base on the back-mounted counterlungs.
- Remove the large sealing O-ring from the counterlung inlet base.

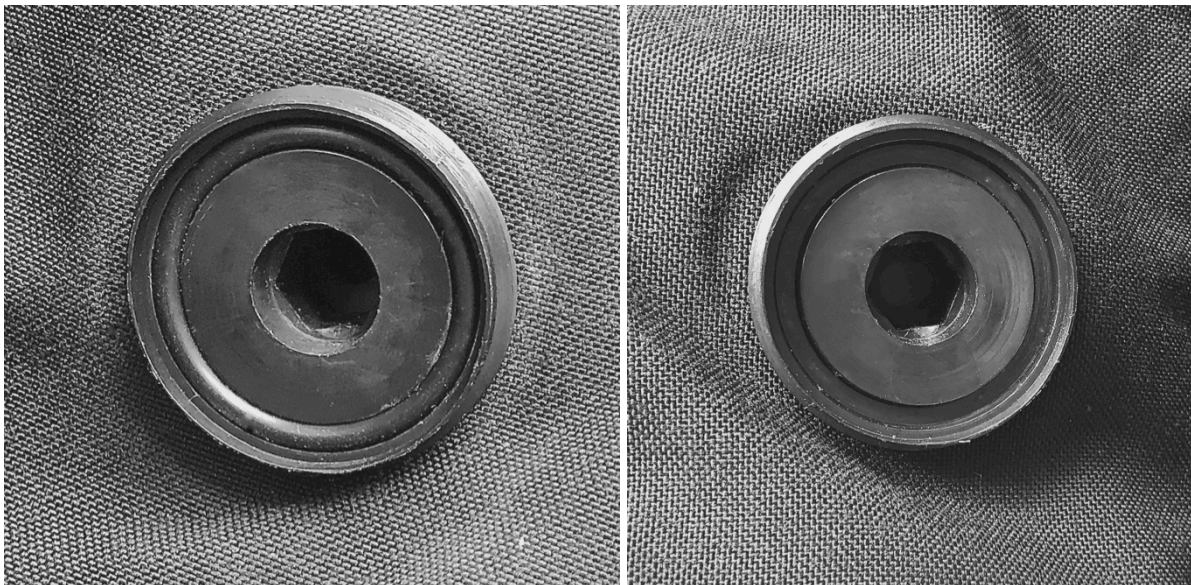

5.9 Remove O-rings from MP counterlung inflator hose

- Unscrew (counter clockwise) the MP hose from the inlet elbow.
- Remove the O-rings from the MP hose.



5.10 When GC3 Flowstop is fitted: remove O-rings from both ends of MP hose

- Remove the O-rings from both the protruding as well as the recessed connection end of the hose.



AP50 Medium Pressure (MP) hose disassembly

5.11 Remove circlip from snap connector body

- Use small pliers to remove the circlip from the snap connector body.
- Take care not to widen the circlip, as it will otherwise not be usable again during assembly.

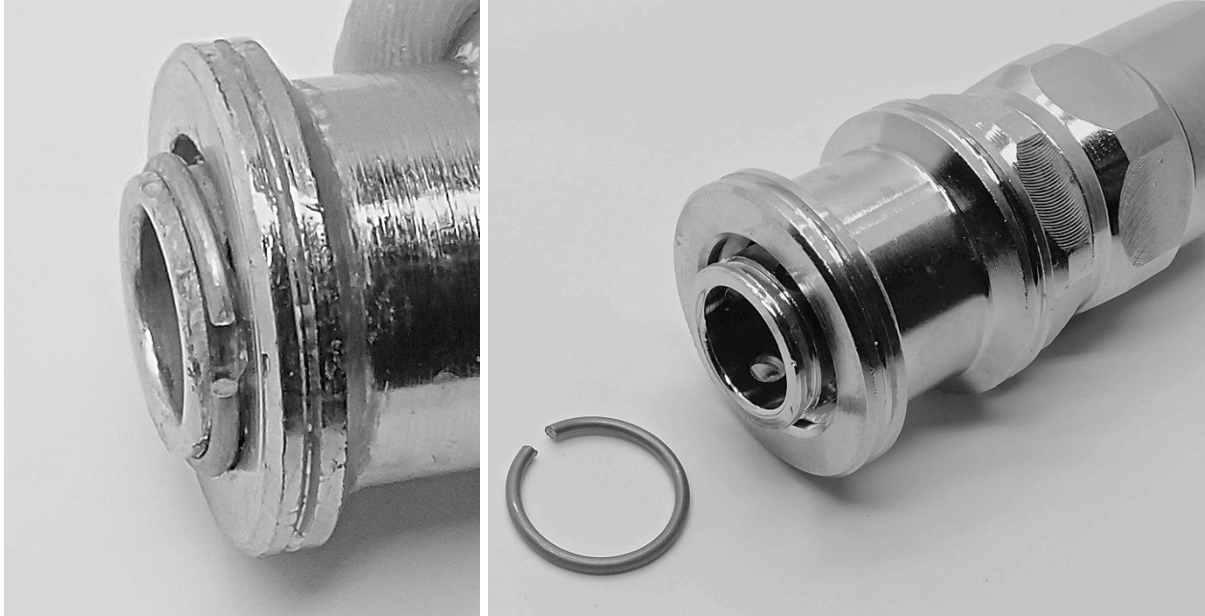

5.12 Remove sliding collar from snap connector body

- Just pull it off.



5.13 Remove spring from snap connector body

- Just pull it off.
- Make sure you do not inadvertently let the ball bearings drop out in the process.

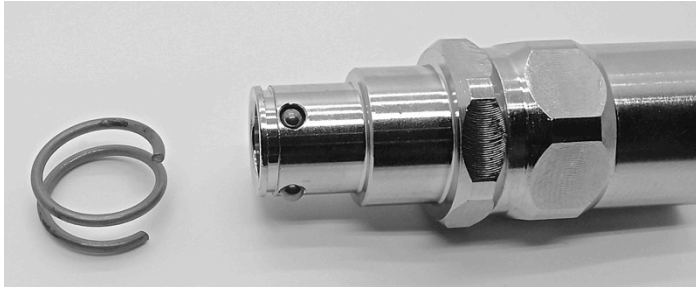

5.14 Remove 4 ball bearings from snap connector body

- Use a small tray to catch the 4 ball bearings to avoid losing them.



5.15 Unscrew Schraeder valve from snap connector body

- Use the AP50E tool or equivalent to unscrew the Schraeder valve from the body.
- Unscrew counter-clockwise.
- This Schraeder valve needs to be replaced during service.

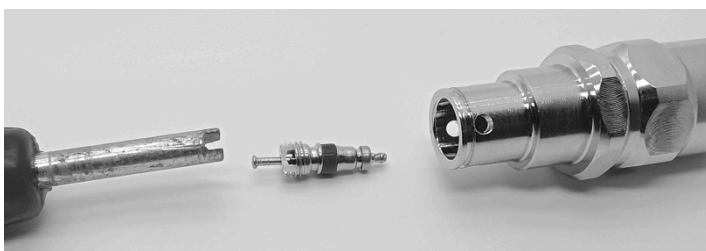
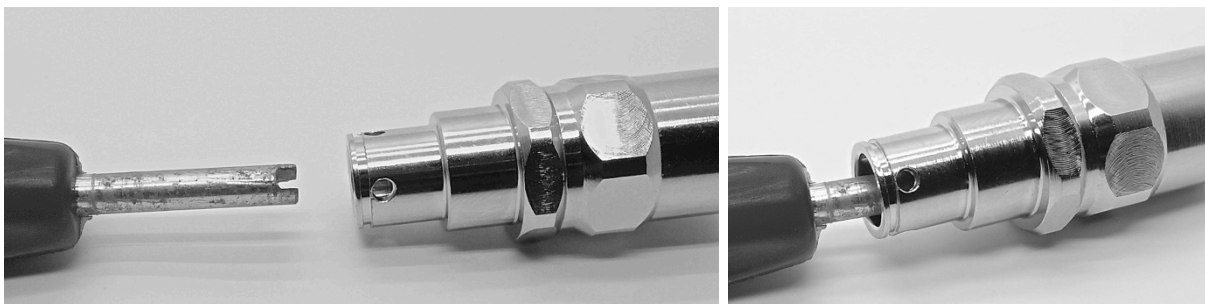

5.16 Remove O-ring from snap connector body

- Use a curved O-ring pick to remove this O-ring.
- This O-ring needs to be replaced during service.

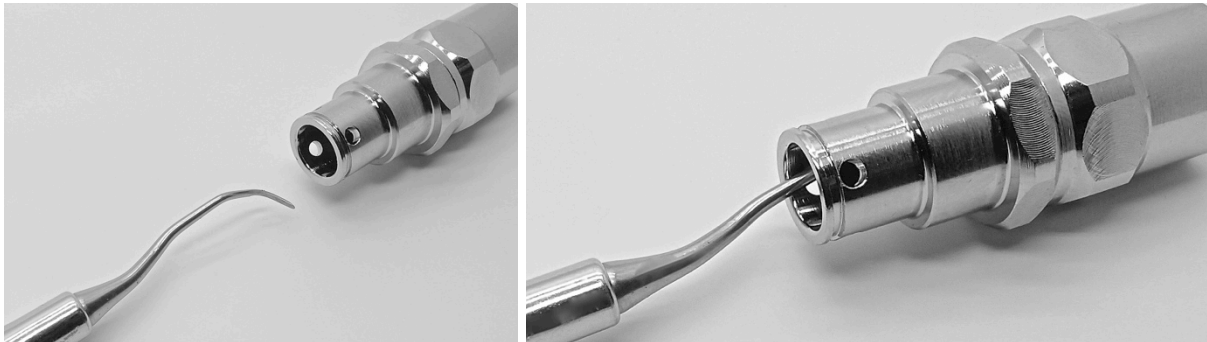

This completes the disassembly of the AP50 Medium Pressure hose.

6. Clean and Replace Service Parts

The servicing of the RBV07 Swivel inflator contains 4 “action groups”:

1. Removing and binning all parts that should be replaced. This includes all O-rings.
2. Depending on the gas content the RBV07 Swivel inflator is exposed to, keep it in oxygen service. The CGA (Compressed Gas Association), US Navy, UK’s HSE and the EIGA (European Industrial Gas Association) all recommend that breathing gasses with an oxygen content of 23.5% or higher should be treated as 100% oxygen. However, some technical training agencies still use 40% as the maximum percentage that is allowed for equipment that is not in oxygen service.
AP Diving advises to err on the side of safety, and to use the value of 23.5% as the cutoff percentage beyond which the equipment must be in oxygen service.
If in doubt: keep it in oxygen service, as that only takes a little bit more effort.
3. Ultrasonic-cleaning of all disassembled metal parts. This is mandatory if the RBV07 Swivel inflator is to be kept in oxygen service, but recommended in all other servicing situations.
4. Lightly grease new parts, fit them, and re-assemble the RBV07 Swivel inflator with the correct tools and the correct torques. Use oxygen-compatible grease, and avoid contaminating the metal parts after cleaning. Use the smallest amount of grease possible.

The use of rubber gloves while re-assembling the RBV07 Swivel inflator is mandatory if the RBV07 is to be kept in oxygen service. This is to avoid rendering the RBV07 Swivel inflator unclean due to human touch (skin oils, sweat).

As described in chapter 4.1, the following service kits are available that contain the parts that need to be replaced when servicing the RBV07:

<u>RBV07KIT</u>	<u>Single Diluent Swivel Inflator + outlet Hose + Counterlung Inlet Service Kit</u>	
	[Note: Does not include any AP50 Hose service parts – sold separately – see AP50KIT	
BS006N70	O Ring	1
BS010N70	O Ring	3
BS111N70	O Ring	1
AP43B	BLUE Diluent Button	1
Outlet Hose		
BS903N70	O Ring	1
BS010N70	O Ring	1
Counterlung Inlet Base		
BS222N50	O Ring for AP35E Din post base	1

<u>RBV07AKIT</u>	<u>Single Oxygen Swivel Inflator + outlet Hose + Counterlung Inlet Service Kit</u>	
	[Note: Does not include any AP50 snap-connector Hose service parts – sold separately – see AP50KIT	
BS006N70	O Ring	1
BS010N70	O Ring	3
BS111N70	O Ring	1
AP43G	GREEN Oxygen Button	1
Outlet Hose:		
BS903N70	O Ring	1
BS010N70	O Ring	1
Counterlung Inlet Base:		
BS222N50	O Ring for AP35E Din post base	1

<u>RBV07/DUAL/KIT</u>	<u>Dual Diluent Swivel Inflator + outlet Hose + Counterlung Inlet Service Kit</u>	
	[Note: Does not include any AP50 snap-connector Hose service parts – sold separately – see AP50KIT	
BS006N70	O Ring	2
BS010N70	O Ring	5
BS111N70	O Ring	2
AP43B	BLUE Diluent Button	2
Outlet Hose:		
BS903N70	O Ring	1
BS010N70	O Ring	1
Counterlung Inlet Base:		
BS222N50	O Ring for AP35E Din post base	1

<u>RBV07A/DUAL/KIT</u>	<u>Dual Oxygen Swivel Inflator + outlet Hose + Counterlung Inlet Service Kit</u>	
	[Note: Does not include any AP50 snap-connector Hose service parts – sold separately – see AP50KIT	
BS006N70	O Ring	2
BS010N70	O Ring	5
BS111N70	O Ring	2
AP43G	GREEN Oxygen Button	2
Outlet Hose:		
BS903N70	O Ring	1
BS010N70	O Ring	1
Counterlung Inlet Base:		
BS222N50	O Ring for AP35E Din post base	1

<u>RBV07/SO/KIT</u>	<u>Single Diluent Swivel Inflator (with Shutoff) + outlet Hose + Counterlung Inlet + Flowstop outlet-Hose Service Kit</u>	
	[Note: Does not include a GC3A Flowstop Service Kit or any AP50 Hose service parts – sold separately – see AP50KIT	
BS006N70	O Ring	1
BS010N70	O Ring	4
BS111N70	O Ring	1
AP43B	BLUE Diluent Button	1
Flowstop to ADV Hose (RB20/36):		
BS010N70	O Ring	2
Outlet Hose:		
BS903N70	O Ring	1
BS010N70	O Ring	1
Counterlung Inlet Base:		
BS222N50	O Ring for AP35E Din post base	1

<u>RBV07A/SO/KIT</u>	<u>Single Oxygen Swivel Inflator (with Shutoff) + outlet Hose + Counterlung Inlet + Flowstop outlet-Hose Service Kit</u>	
	[Note: Does not include a GC3A Flowstop Service Kit or any AP50 Hose service parts – sold separately – see AP50KIT	
BS006N70	O Ring	1
BS010N70	O Ring	4
BS111N70	O Ring	1
AP43G	GREEN Oxygen Button	1
Flowstop to Solenoid Hose (RB20/84):		
BS010N70	O Ring	2

Outlet Hose:		
BS903N70	O Ring	1
BS010N70	O Ring	1
Counterlung Inlet Base:		
BS222N50	O Ring for AP35E Din post base	1

<u>RBV07/DUAL/SO/KIT</u>	<u>Dual Diluent Swivel Inflator (with Shutoff) + outlet Hose + Counterlung Inlet + Flowstop outlet-Hose Service Kit</u>	
	[Note: Does not include a GC3A Flowstop Service Kit or any AP50 Hose service parts – sold separately – see AP50KIT	
BS006N70	O Ring	2
BS010N70	O Ring	6
BS111N70	O Ring	2
AP43B	BLUE Diluent Button	2
Flowstop to ADV Hose (RB20/36):		
BS010N70	O Ring	2
Outlet Hose		
BS903N70	O Ring	1
BS010N70	O Ring	1
Counterlung Inlet Base		
BS222N50	O Ring for AP35E Din post base	1

<u>RBV07A/DUAL/SO/KIT</u>	<u>Dual Oxygen Swivel Inflator (with Shutoff) + outlet Hose + Counterlung Inlet + Flowstop outlet-Hose Service Kit</u>	
	[Note: Does not include a GC3A Flowstop Service Kit or any AP50 Hose service parts – sold separately – see AP50KIT	
BS006N70	O Ring	2
BS010N70	O Ring	6
BS111N70	O Ring	2
AP43G	GREEN Oxygen Button	2
Flowstop to Solenoid Hose (RB20/84):		
BS010N70	O Ring	2
Outlet Hose		
BS903N70	O Ring	1
BS010N70	O Ring	1
Counterlung Inlet Base		
BS222N50	O Ring for AP35E Din post base	1

<u>AP50KIT</u>	<u>AP50 snap connector Hose Service Kit</u>	
AP100/44	Core Valve	1
BS011N70	O Ring	1
BS903N70	O Ring	1

6.1 Ultrasonically clean deposits from all metal parts

Clean deposits from all metal parts, like chalk and salt.



WARNING: Do NOT use aggressive chemicals. They might damage the metal plating. Use an ultrasonic cleaning bath with a suitable cleaning fluid instead. A good cleaning fluid is Biox "O2" immersion fluid. See WWW.BIOXINT.COM for further information and distributors.

6.2 Replace all O-rings with new ones from the Service Kit



WARNING:

- Replace all O-rings: do NOT re-use old ones.
- ONLY use original parts from APD, to make sure the O-rings:
 - o Are the exact size
 - o Are of the correct material (especially important in a high oxygen content and overpressure environment)
 - o Are of the correct stiffness (degrees Shore).
- Make sure you use only oxygen-compatible grease.
- Also make sure you only use oxygen-clean and oxygen-compatible replacement parts. All APD-supplied O-rings in the service kit are made from Nitrile and as such are oxygen compatible. However, they still need to stay or be made oxygen-clean.
- Last but not least: avoid touching oxygen-clean parts after cleaning with your bare hands. Human body sweat and grease are not oxygen-compatible. So use rubber gloves (e.g. surgical) when re-assembling the RBV07 Swivel inflator.
- For photographic clarity no rubber gloves are worn on the photos in this manual.

6.3 How to lightly grease O-rings

When greasing O-rings, make sure NOT to use too much grease.

Especially O₂ compatible grease has the potential to become stiffer over time, which may cause a hardened clot of grease to become a source for leaking.

The best way to grease O-rings is using a simple “grease bag”.

A grease bag is a clean and clear plastic bag, into which you put a small amount of grease. Optionally you can make two bags: one with O₂ compatible grease, and one with normal silicone grease. Make sure you label them properly to avoid mixing them up! Also put a date on it, so you know how old your grease bag is. Don't use them longer than a year.

A nice advantage of using a grease bag is that you use only a tiny amount of grease for greasing many O-rings, so there is little waste.

We recommend that you use resealable bags, e.g. the ones with a plastic zipper, typically used for airtight food storage. This allows you to zip up the bag after use, keeping the contents clean for repeated use.

The simple steps are as follows:

- Take a plastic bag and deposit a **SMALL** amount of grease in it.

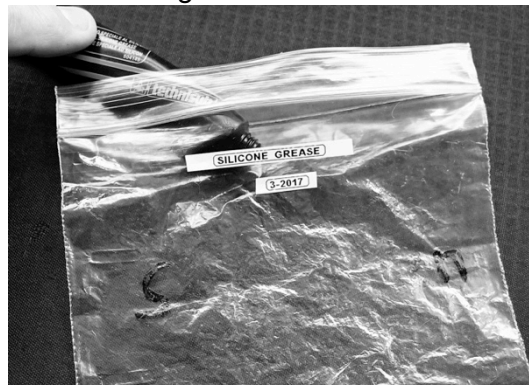

- Massage this grease all around the bag until it is evenly distributed over the inside surface area.
- Take the O-rings to be greased out of their storage container, either using gloves or using an O₂-cleaned instrument like a dentist hook.



- Drop them in the grease bag, and from the outside of the bag move them around with your fingers, making sure they get in full contact with the grease.



- Open the bag, and using a clean instrument like a dentist hook, take the now properly greased O-rings out.
- Inspect them to make absolutely sure that the grease is evenly and lightly distributed on the O-rings and that there are no areas of excess grease - no globs or strands.
- Fit them where they belong on your diving equipment, still making sure not to touch them with your bare hands.

7. Assembly Instructions

⚠ WARNING: When assembling the RBV07 Swivel inflator, use rubber gloves to avoid contaminating it while assembling, rendering it not oxygen-clean anymore. This applies especially to the oxygen versions of the RBV07.

7.1 General overview: main assembly steps

Despite the fact that all eight models of the RBV07 range of inflators have different layouts and functionality, the service procedures for these inflators have a lot in common. For that reason, the assembly steps of the 8 different models are not described separately for each one, but are consolidated into steps that are common to all.

There are four main steps in the assembly process:

1. Replace all old O-rings, lightly greasing the new ones with Oxygen compatible lube.
2. Push the inflator spindles back into the inflator bodies and screw them back onto a new blue or green push button.
3. Attach the swivelling inflator bodies (the parts with the blue or green push buttons) back onto the outlet bodies by screwing the connecting locking nuts back into the outlet bodies.
4. Screw all inlet and outlet adapters back into their bodies:
 - a. The 5/16" inflator stems,
 - b. The 5/16"-9/16" adapters and
 - c. The GC3 Flowstop isolators (where fitted).

ATTENTION: Make sure the inflator stems, adapters and Flowstop isolators go into the correct holes in the inflator bodies. Use the pictures in chapter 3 as a reference.

7.2 Place a new O-ring into the inflator body



7.3 Screw the blue or green push button onto the inflator spindle

- Fit new O-rings onto the inflator spindle.



Fit a new push button.

- **ATTENTION:** always use a new push button during service; **NEVER reuse** the old one. The push button “sticks” to the inflator spindle by friction (the nyloc effect). Reusing an old push button will cause it to have less friction due to the thread getting worn out, which may cause the push button to unscrew itself inadvertently during use.
- Use a non-slip surface that has sufficient gliding resistance, like a piece of rubber from a car or bike inner tube.
- Place the spring on top of the new push button.

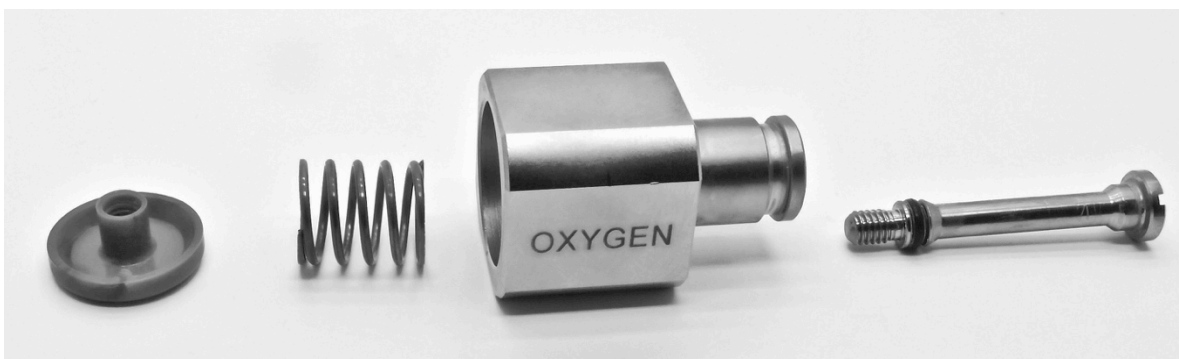

- Place the inflator body over the push button and its fitted spring, and push the assembly down onto the non-slip rubber surface. The aim of the rubber surface is to prevent rotation of the push button while screwing the inflator spindle back into the push button.
- As you keep pushing down on the inflator body, push the inflator spindle into the inflator body until it touches the threaded end of the push button.
- Use a screwdriver to **GENTLY** screw the inflator spindle into the push button. Do **NOT** use force. Remember that you are screwing a hard metal part into a softer plastic part, and that the push button is prevented from unscrewing by the nyloc friction effect, not by the force with which it is screwed onto the spindle.



- **NOTE:** there is a small number of early RBV07s in the field that have inflator spindles without a groove. These spindles can be screwed back in by first pushing on the push button, so that the inflator spindle sticks out. The exposed spindle end can now be screwed in using pliers. See picture below:

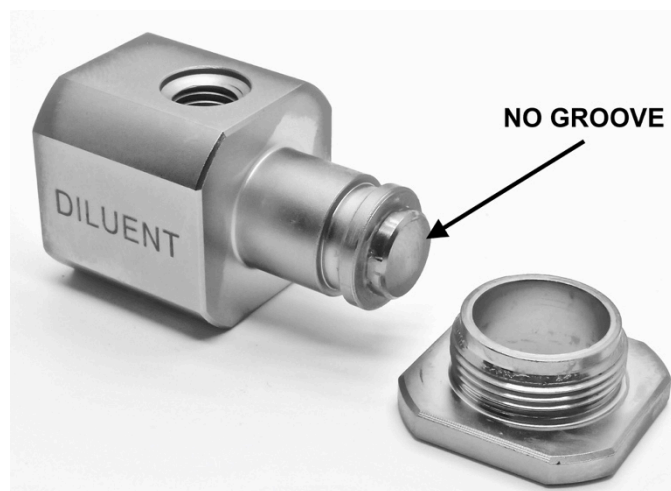

7.4 Fit a new O-ring onto the inflater body and locking ring

- Push the locking nut over the stem of the inflater body, with the thread of the locking nut facing to the outside.
- Fit a new large O-ring onto the stem of the inflater body.
ATTENTION: Make absolutely sure you use the correct size and hardness O-ring, as this O-ring acts both as a gas seal as well as a locking device, preventing the locking nut from detaching from the inflater body.



7.5 Connect the inflator body to the outlet body

- Clamp the outlet body into a bench vice.
- **ATTENTION:** when using the vice, make sure to fit it with soft jaws (plastic or fibre). This avoids damaging the clamped outlet body and its nickel-plated coating.
- For the same reason avoid the use of an adjustable spanner, as it might damage the coating of the inflator body and locking ring.

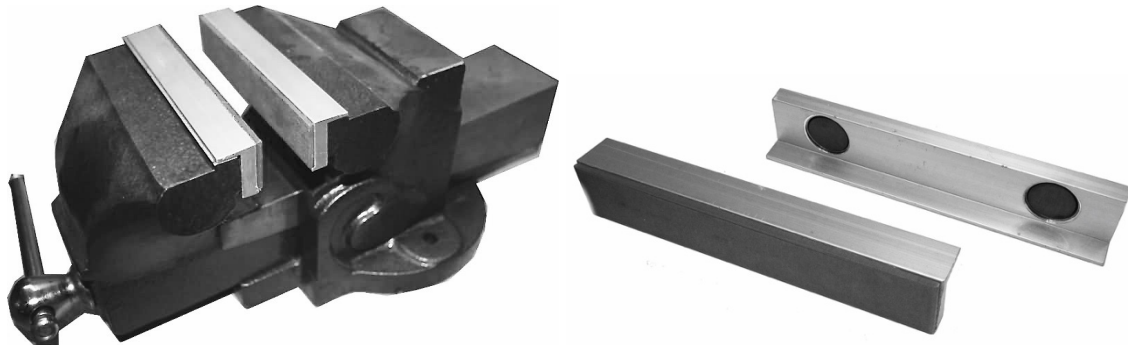

- Use a 24 mm spanner to screw the inflator body clockwise into the outlet body.
- **ATTENTION:** Make sure the jaw of the spanner **ONLY** touches the inflator body and the locking ring, i.e. the parts with "OXYGEN" or "DILUENT" laser engraving and containing the blue or green push button. The jaw of the spanner should **NOT** touch the outlet body.
- Use the mark you made with a permanent marker during disassembly as a reference as to how far you need to screw the locking nut into the outlet body.



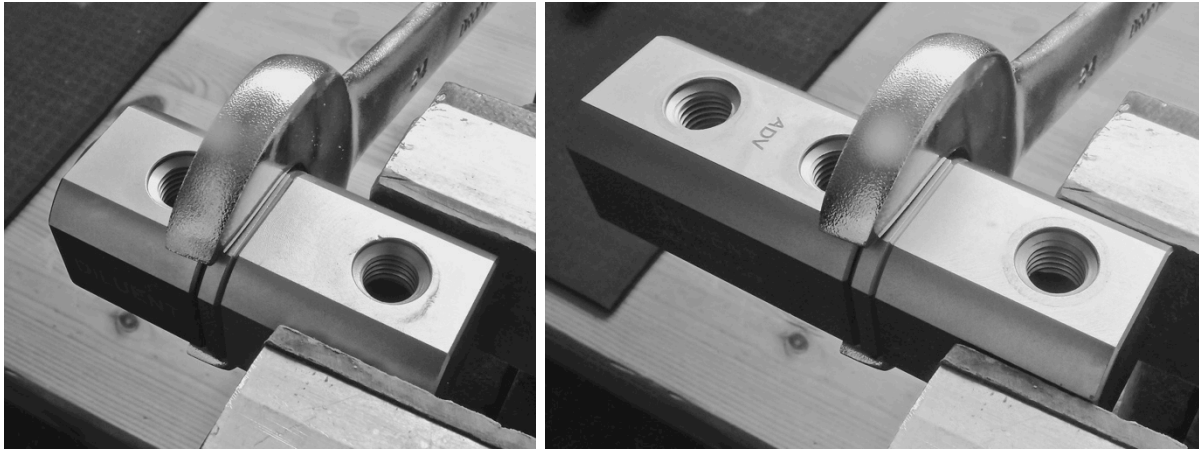

7.6 Screw the 5/16"-9/16" adapter(s) back into the outlet body or inflator body

- Fit new O-rings onto the base of the adapter(s).

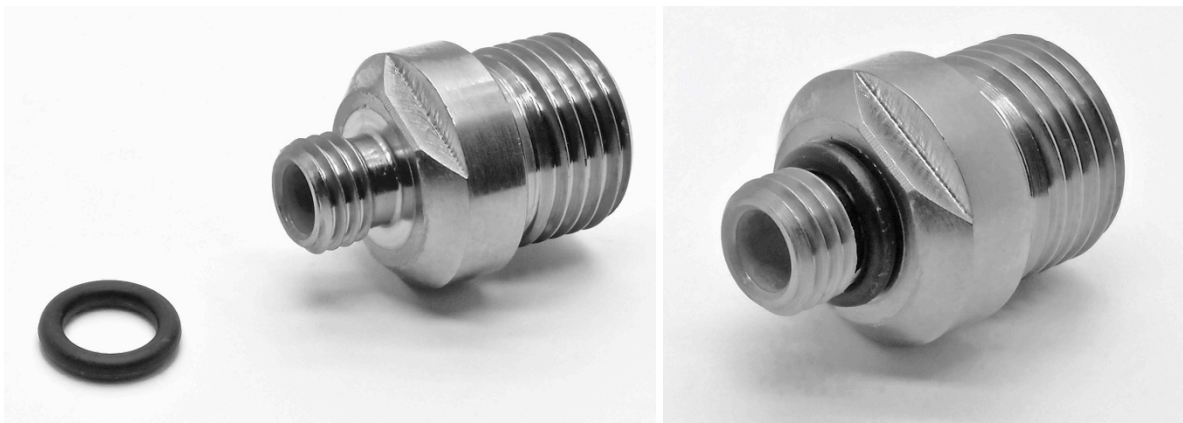

- Use a 5 mm Allen key to screw the adapter back into the outlet body or inflator body.

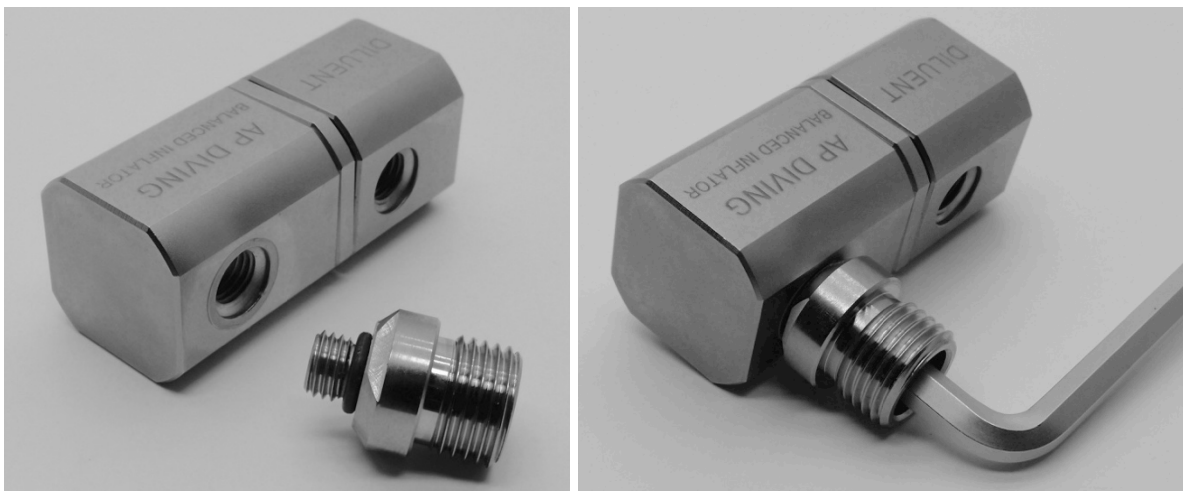

- Special care needs to be taken when refitting the 5/16"-9/16" adapter into the synthetic dual outlet body. Use a 5 mm **torque wrench** to nip up the 5/16"-9/16" adapter into the dual outlet body. Use a torque setting of only **4 Newton-Meter**.
- **ATTENTION:** Make sure you DO use a torque wrench and do NOT use a higher torque. Even though the 5/16" female connection of the dual outlet body is fitted with a metal insert, using too high a torque force could cause this metal insert to come undone from the black synthetic part it is moulded into.
- If you do not have a low-value torque wrench, alternatively you can use a right-angled 5mm Allen key:
 - o Screw the adapter in until you feel that it just goes tight against the body and then nip it up gently about another **1/16th-1/8th of a turn. No more than that.**
 - o Do not use excessive force as over-tightening may damage the threads.
 - o It is recommended that you use a right-angled Allen key rather than a T-piece version, so that the maximum leverage you can apply is limited.
- Once the metal insert is damaged, it becomes unusable and dangerous in operational use. In that case the complete dual outlet body HAS to be discarded and replaced.



7.7 Screw the GC3 Flowstop isolator back into the 5/16"-9/16" adapter

- **ATTENTION:** This step only applies to the RBV07(A)/SO and RBV07(A)/DUAL/SO versions of the inflator, which are fitted with a GC3 in-line gas isolator.
- Use a 14 mm spanner to screw the GC3 Flowstop back into its associated adapter.



7.8 Screw the 5/16" inflator stem(s) back into the inflator body

- Fit new O-rings onto the base of the inflator stem(s).
- Use an 8 mm spanner to screw the inflator stem back into the inflator body.

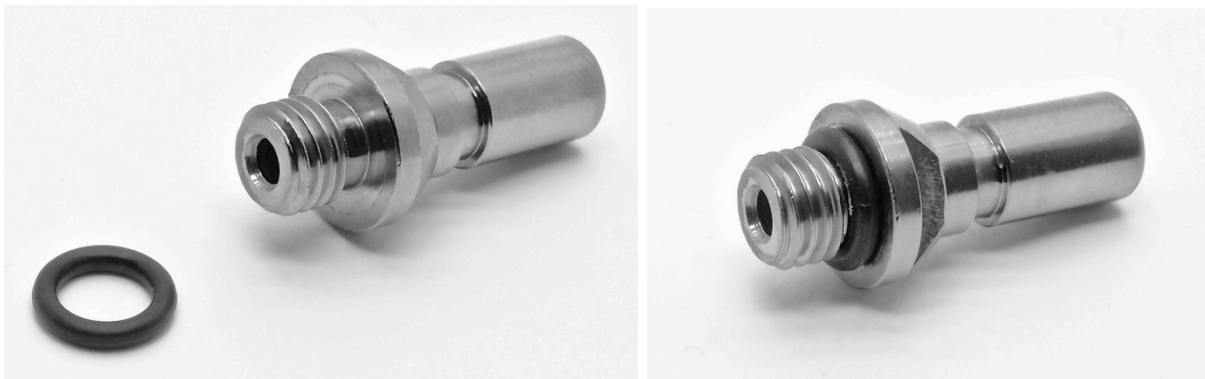



This completes the assembly of the inflater assembly with its inlet and outlet adapters.

7.9 Fit new O-rings to MP counterlung inflater hose

- Fit new O-rings onto the MP hose.
- Screw (clockwise) the MP hose back into the inlet elbow.
 - o Do **NOT** use force. Realise that you are screwing a metal hose-end into a plastic part. Using force might damage the thread within the elbow.
 - o Remember that sealing is through the O-ring, **not** through force.



7.10 Fit low profile counterlung inlet elbow back onto counterlung

- Place a new large sealing O-ring in the counterlung inlet base.
- Screw (clockwise) the knurled locking ring that holds the low profile counterlung inlet elbow back onto the inlet base of the back-mounted counterlungs.
 - o Make sure the large O-ring doesn't get dislodged in the process. Verify this by making sure the inlet elbow can't rotate anymore, and by executing the positive and negative counterlung leak tests.

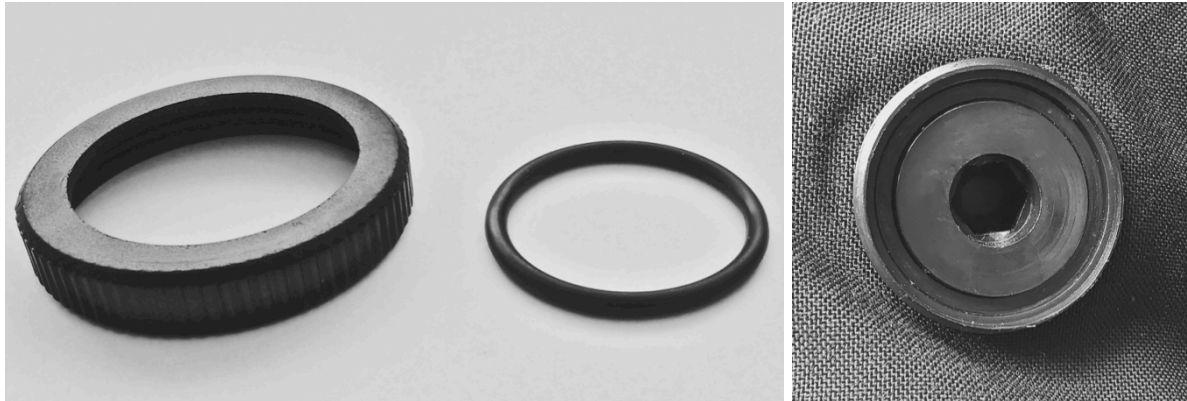

7.11 When a GC3 Flowstop is fitted: fit new O-rings to both ends of MP hose

- Fit new O-rings to both hose ends.
- **ATTENTION:** make sure to fit the hose the correct way around. Notice that the ends are different:
 - o The end with the protruding connection goes onto the solenoid; the end with the recessed connection goes onto the GC3 Flowstop.
 - o If the hose is fitted the wrong way around, you will not be able to screw the hose end all the way down onto the GC3 Flowstop, showing exposed threads (see picture below on the left).
 - o In that case neither end of the hose will be properly secured.

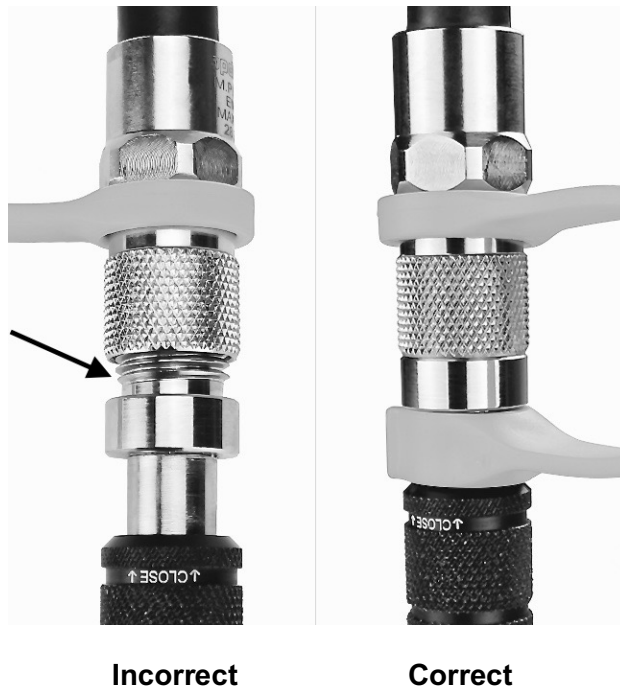

The connection on the left is incorrect, as a result of the hose being connected the wrong way around. Notice the exposed threads.



GC3 Flowstop end



Solenoid end

7.12 Place the yellow locking strap back onto the GC3 isolator.

- When fitting the locking strap to the Flowstop/hose assembly, it is important to fit the loop **above** the knurled area of the hose end. If it is fitted below the hose end, the strap can slide off easily and may impede the path of the black knurled slider, preventing its proper operation (see below right).
- See also the remarks in paragraph 3.2 on the recommended position of the black collar of the GC3 Flowstop isolator.
- See pictures below for correct and incorrect fitting of the locking strap:



Locking strap fitted **correctly**:
above the knurled chrome area



Locking strap fitted **incorrectly**:
below the knurled chrome area

AP50 hose assembly

7.13 Fit new O-ring inside snap connector body

- Fit a new lightly greased O-ring to the inside of the snap connector body.



7.14 Screw new Schraeder valve into snap connector body

- Use tool AP50E or equivalent to screw a new Schraeder valve into the snap connector body.
- Screw clockwise. Do not use force.



7.15 Push 4 ball bearings back into snap connector body

- Lightly grease the ball bearings before putting them back in place.
 - o This will also help to prevent them falling out again in the process.
- Perform this and the next action above a tray, so you don't lose the ball bearings if they happen to drop out.
- Check that all 4 ball bearings are in place before proceeding.

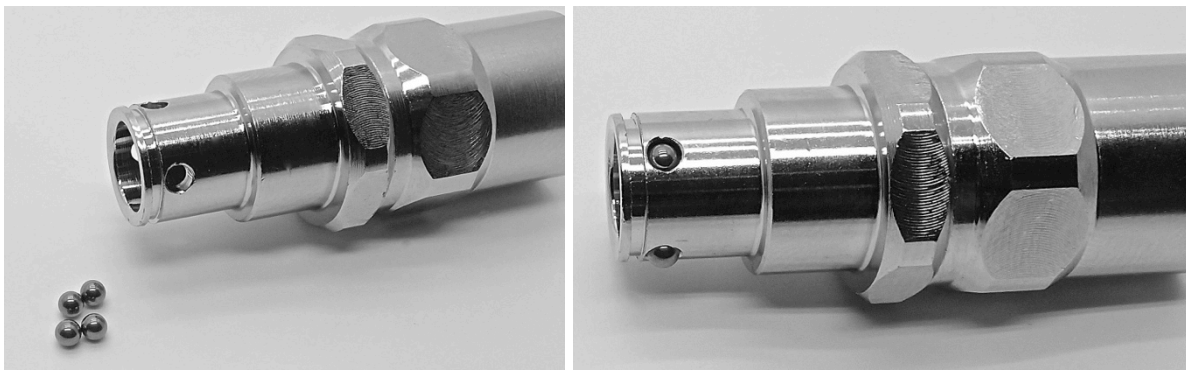

7.16 Put spring onto snap connector body

- Again, make sure you do not lose one of the 4 ball bearings during this step.

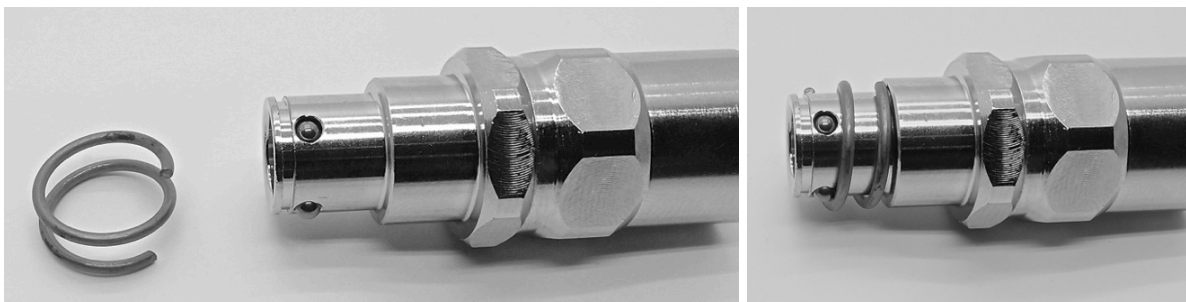

7.17 Push sliding collar onto snap connector body

- The collar can only go on in one way. Push it on with the wider opening facing the hose and the smaller opening facing the circlip, to be fitted in the next step.
- Again, make sure you do not lose one of the ball bearings during this step.



7.18 Refit circlip onto snap connector body

- Before fitting it back on, make sure it hasn't been stretched and become too wide during removal. If unsure: use a new circlip.
-  **WARNING:** If that is the case, it may come off again inadvertently during use, rendering the whole hose connection and anything it is attached to inoperable!
- Just push it back on. Check that you can rotate it in its groove after fitting. It should rotate, but only with slight difficulty. If it rotates too easily, it may have become too wide. In that case remove it, tighten it up and refit it – or fit a new one.



This completes the re-assembly of the AP50 Medium Pressure hose.

8. Testing Instructions

8.1 Test for leaks and proper operation

- Close the GC3 Flowstop slider (i.e. pull slider towards the "CLOSE" position), when fitted.
- Attach MP hoses to the inlet inflator stems and pressurise them.
- Leave the 5/16"-9/16" outlet adapters open for now (i.e. do not attach an MP hose to them yet).
- Test the green or blue push buttons: pushing them should let gas flow out of the outlet adapters; releasing them should block the gas flow completely. Listen and feel to the outlet adapter to verify that.
 - o **TIP:** Once pressurised, close the valves of the cylinders connected to the MP hoses to the inlet inflator stems again. Then monitor the HP gauges connected to the first stages of these cylinders. If there are no leaks, the pressure shouldn't drop.
- Move the slider of the GC3 Flowstop (when fitted) to the "OPEN" position and verify gas is continuously flowing through the inflator, regardless of the push button operation.
- Next attach an MP outlet hose to the 5/16"-9/16" outlet adapter and (when fitted) to the GC3 Flowstop.
 - o **TIP:** When available, it is probably easiest to fit the inflator to an Inspiration rebreather as you would normally do, with all the inlet and outlet MP hoses attached and pressurised.
- Submerge the inflator in a bucket of water and monitor it for any bubbles - indicating leaks. Rotate the swivel while submerged and push the buttons.
 - o Alternatively spray some soapy water (water with some detergent) on the RBV07 and watch for bubbles. There shouldn't be any.
- Finally perform the usual rebreather positive and negative leak tests with the serviced inflators fitted in order to also check all serviced hose connections.
- If all tests are passed OK - your maintenance has been successful.