



CO₂ Sensor

User Instruction Manual

Contents

Dangers of CO₂.....3

Important Information.....3

Introduction.....4

CO₂ Sensor Features.....5

CO₂ Sensor Configuration.....6

CO₂ Sensor Assembly.....7

Pre-Dive Operation.....10

Dive Mode Operation.....11

In The Event of a Warning.....14

DiveStore and PC Connection.....14

Dive Log / Log Viewer.....15

Maintenance.....15

Manufacturer.....16

EC TYPE Approval.....16

EC PPE Article 11B Approval.....16

Dangers of CO₂

CO₂, Carbon dioxide, is a product of respiration with each exhaled breath comprising approximately 4% CO₂. If inhaled in sufficient concentration it can cause unconsciousness and death. The rebreather's scrubber is designed to absorb exhaled CO₂ but in the event that the scrubber is ineffective for some reason then it is desirable to have a warning system that directly measures the gas content and warns the diver. Typical reasons for experiencing too much CO₂ in a rebreather include over-used material, wrong grade of material, scratched or worn scrubber components, incorrect assembly – over-filling or under-filling the scrubber, faulty assembly or forgetting to fit or lubricate O rings.

Important Information

- During pre-dive, always carry out a full calibration of the O₂ sensors as the CO₂ Sensor is zeroed at the same time. Not doing so could cause inaccurate CO₂ warnings.
- Always ensure a fresh CO₂ sensor protector, drying cartridge, (RB120/1) is fitted every 20-30 hours of diving.
- Storing the sensor protector, drying cartridge, in a humid environment markedly shortens the protector's useful life.
- Venting the loop between dives extends the life of the CO₂ sensor protector, drying cartridge (RB120/1). Just unscrewing the hose from the lid and leaving open for 5 minutes is usually sufficient. Please ensure it is re-connected before diving again.
- Always protect the CO₂ sensor face from moisture to prevent unnecessary damage.
- DO NOT begin a dive with a CO₂ Sensor alarm.
- When you experience a CO₂ alarm, ascend and consider bailing out from the rebreather monitoring for symptoms of CO₂ poisoning. Remember symptoms of CO₂ poisoning can be difficult to detect or recognise, particularly in raised ppO₂ breathing mixtures – if in doubt, bail out.
- The CO₂ Sensor should **not** be used to determine canister duration.
- NOTE: Any modification to the rebreather can adversely affect the rebreather's performance and is therefore not recommended. Modifications will also invalidate the rebreathers CE Approval and potentially the warranty.

Introduction

The AP Diving CO₂ Sensor is an 'active warning device' designed to alert the diver when the CO₂ content of the breathing loop is approaching a dangerous level. This can be due to depletion of the CO₂ absorbent canister or incorrect assembly resulting in CO₂ bypass of the canister.

There are various methods of CO₂ detection and monitoring that could potentially be used within rebreathing systems, however there are many reasons why integrating these technologies are challenging. The environment within a rebreather has multiple factors that change throughout the dive including pressure, temperature and humidity. These factors need to be addressed in order for any CO₂ sensing technology to be reliable and accurate.

The AP Diving CO₂ Sensor utilises infrared absorption technology to determine the CO₂ content of the breathing loop. The technology uses electronics to measure the wavelength of infrared light, whose characteristics are dependent on the gas the light travels through. Using this technology the partial pressure of CO₂ is measured making it ideal for use in a rebreather. The difficulty in a rebreather is the high humidity present, particularly downstream of the scrubber, as water vapour has a very similar effect on the wavelength to CO₂, which means a CO₂ sensor will mistake water vapour for CO₂ and give inaccurate readings. For this reason, the APD CO₂ Sensor utilises a drying cartridge that consists of a desiccant sandwiched between protective technical membranes to prevent water vapour interfering with the detection of CO₂.

The effect of pressure on the CO₂ Sensor is compensated for with a complex software algorithm. This enables the output of the sensor to be corrected according to changes in pressure experienced during diving.

The CO₂ canister duration within a rebreather varies with depth, diver work rate, temperature, humidity and canister design. An increase in depth or work rate can cause the CO₂ duration of a canister to shorten massively. This doesn't matter greatly during the early phase of a dive on a fresh canister, however if it occurs towards the end of a dive when CO₂ is already breaking through a depleted canister, the rate at which CO₂ increases can dramatically ramp up.

There is also a tendency for some sports divers to try and push the boundaries of the recommended durations of CO₂ absorbent canisters resulting in being subjected to potentially harmful levels of CO₂. The early signs and symptoms of Hypercapnia (CO₂ poisoning) can include headache, confusion, lethargy, raised blood pressure and pulse. However, these symptoms are often masked in elevated oxygen and can be very difficult to recognise in a diving environment. For these reasons, rebreather divers should be aware of their work rate and canister duration and ideally dive with any warning devices available such as the APD Temp-Stik Scrubber monitor and CO₂ Sensor.

CO₂ Sensor Features

The AP Diving CO₂ Sensor (RB120) has been specially developed for use with AP Diving's range of rebreathers, equipped with Vision electronics. The sensor is intended as an option that can be used with or without the APD Scrubber monitor (Temp-stik).

- For use with all AP Diving Rebreathers using Vision Electronics with firmware Version 5.02.01 and onwards installed
- Simple "Plug and Play" operation, V05.02.01 firmware onwards recognises the CO₂ sensor and activates the appropriate displays and warnings.
- Monitors CO₂ levels within the breathing loop and warns the diver prior to the level becoming harmful
- There is a single warning level when the diver should ascend immediately and bailout from the rebreather loop (Warnings are displayed on Vision handset and via the HUD)
- Sensor uses an advanced algorithm that compensates for pressure and temperature
- Disposable desiccant cartridge (consisting of technical membranes and a drying agent) assures accurate monitoring when loop has high humidity levels. (to be changed every 20-30 hours of diving – AP Diving recommend using the 'Elapsed time' feature to monitor protector duration) Protectors to be stored sealed from the atmosphere until ready for use)
- Can be used with or without existing APD Temp-Stik Scrubber monitor
- New mixing chamber supplied for mounting the CO₂ sensor.
- Sensor is checked for operation during Vision Electronics start up.
- Factory calibrated during assembly and simply zeroed during oxygen sensor calibration
- Type Tested for CE approval as an 'Active Warning Device' according to the EN14143:2013 Rebreather standard (Notified Body: SGS United Kingdom Ltd)
- Low power consumption and powered by the Vision rebreather lid batteries
- Suitable for use with all diving gas mixes

CO₂ Sensor Configuration

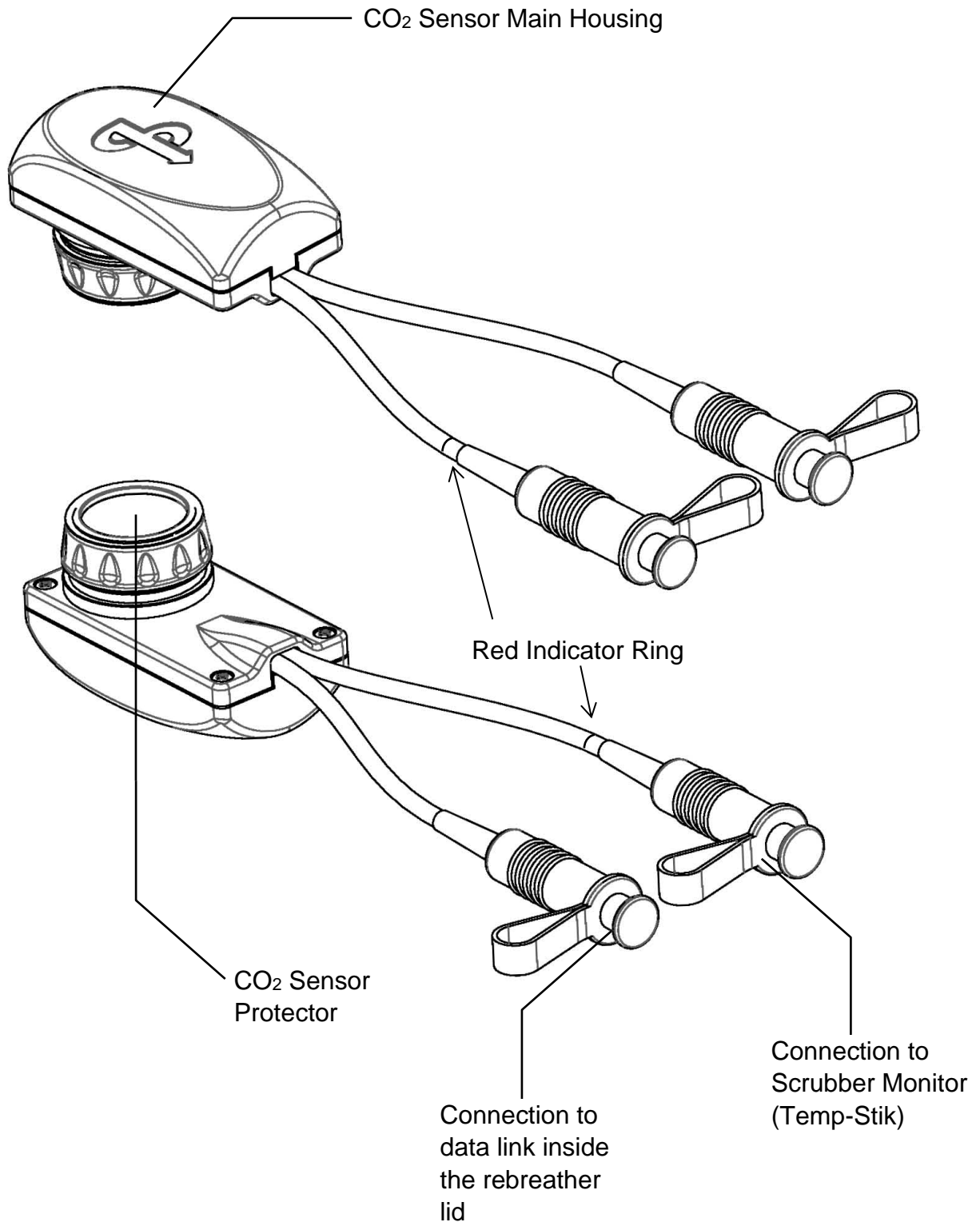

Note: A second Red Indicator Ring is supplied, which can be fitted to the Temp-Stik connector. This gives a quick visual indication as to which cables should be mated.

CO₂ Sensor Assembly

The CO₂ Sensor sits inside the Vision rebreather lid and is powered and communicates via the scrubber/download/upload data link connection. Before assembling the sensor into a rebreather, the software must be updated to Version 5, (available to download from www.apdiving.com/downloads/software)

1. Place the Sensor Holder over the Main Sensor Housing and secure in place by screwing the CO₂ Sensor Protector through the holder into the main housing. Only assemble finger tight - do not over tighten.

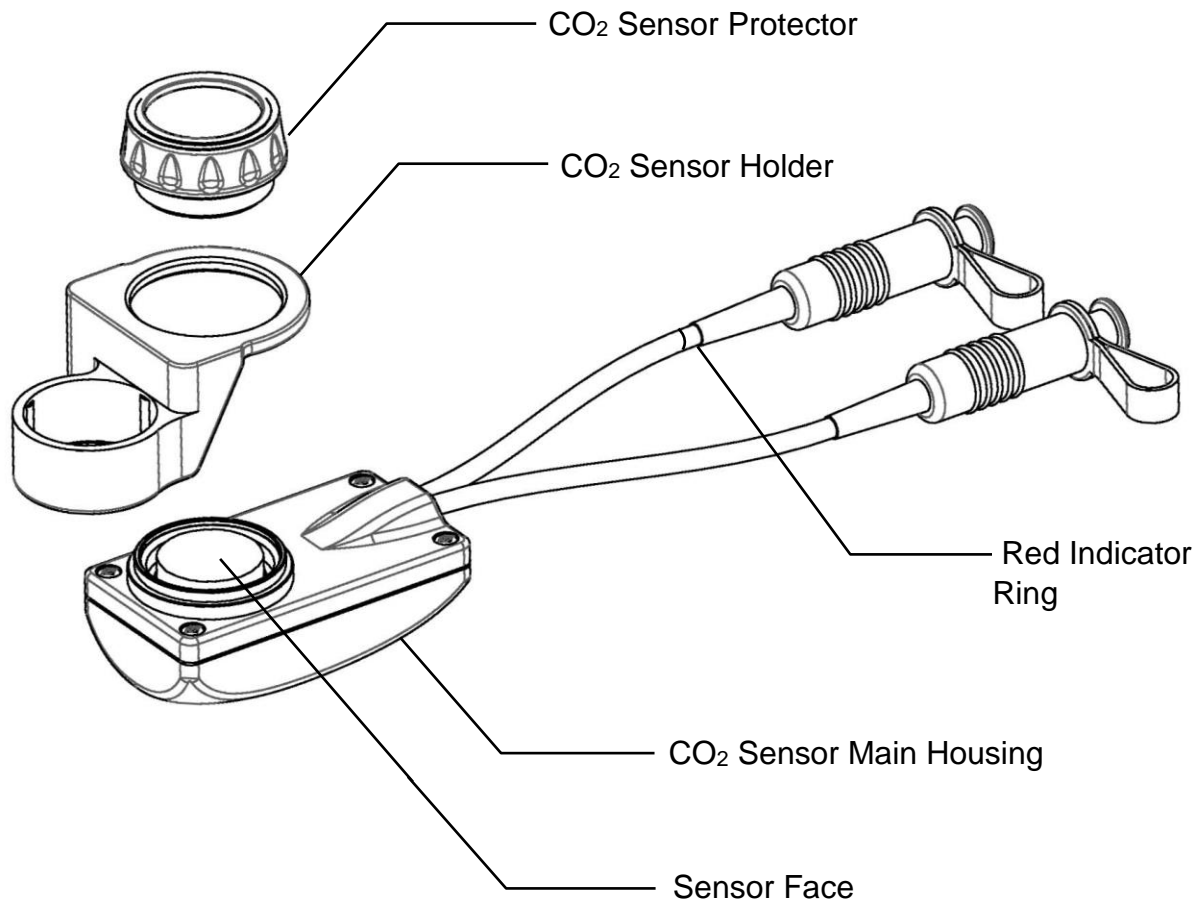

Note: Take care not to damage the Sensor face itself or leave this exposed. Always store the sensor with a used CO₂ Sensor Protector assembled onto it as protection. Before use you should make sure that the sensor face is free from moisture as this can affect the sensors accuracy in use.

Note: Ensure the CO₂ Sensor Protector is screwed in place properly as this is the critical protection against water vapour in the breathing loop. Without this fitted correctly, the sensor will read inaccurately and give you a false alarm.

Note: The CO₂ Sensor housing should not be taken apart, as the internals are encapsulated to protect against moisture damage. If attempted, this could irreversibly damage the Sensors electronics.

2. The Sensor is positioned in the lid by pushing the Sensor Holder over the tube that sits above the solenoid on the mixing chamber.

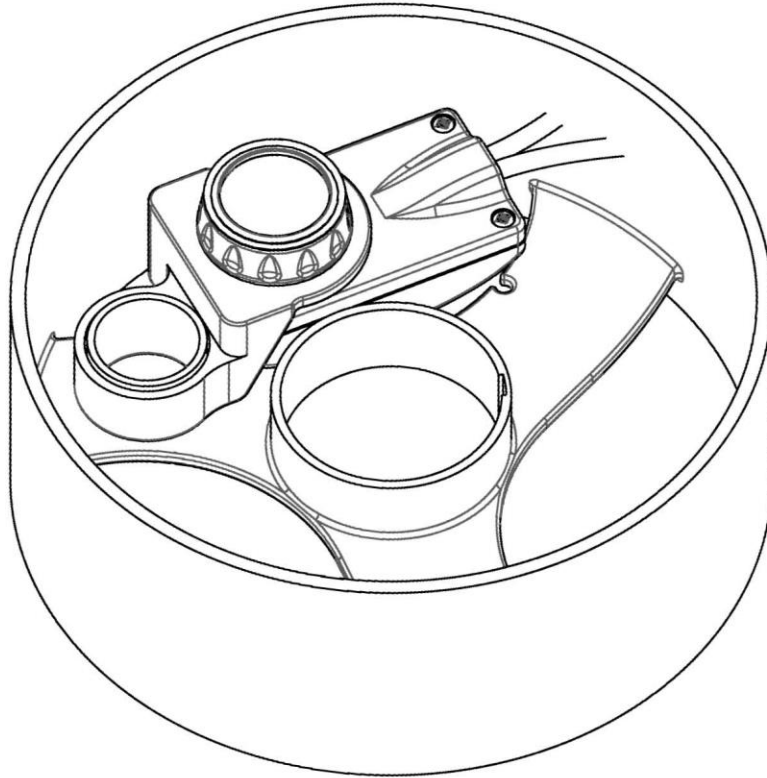

3. The mixing chamber is then placed onto the lid and secured by the mixing chamber locking ring as normal.

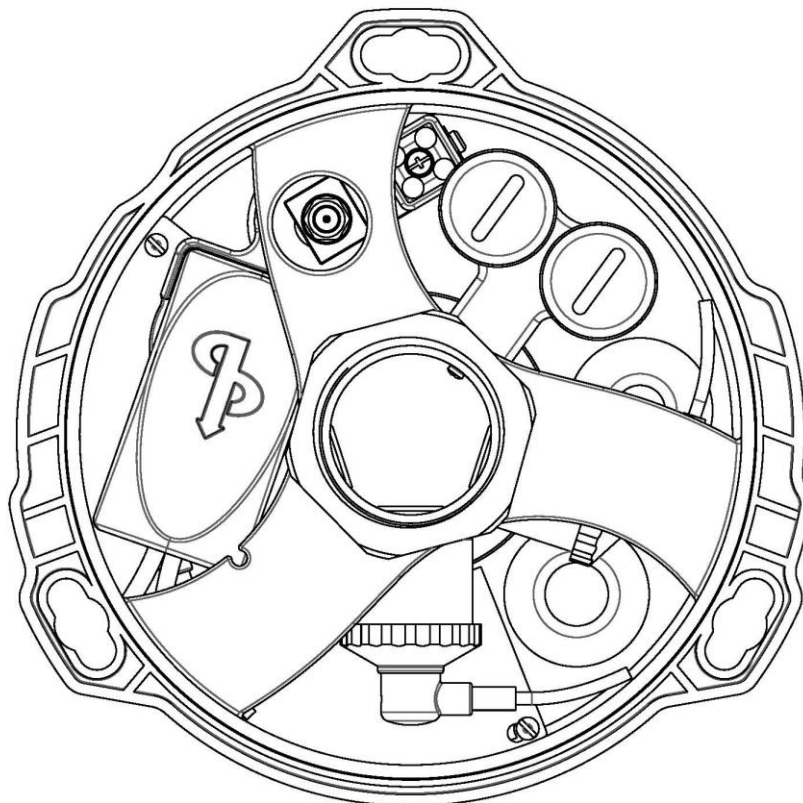

4. Connect the CO₂ sensor to the datalink from the rebreather lid and to the Temp-Stik (if fitted, this is identified with red indicator rings, a spare red indicator ring is provided for retro fit). This is done by pushing the Fischer connectors together with the red dots on the connector bodies aligned. **Check that Fischer connector contacts are clean and dry before mating.** When connected, push any remaining cables into the mixing chamber, ensuring cables do not dangle below and ensure that cable is not trapped by the scrubber spacer

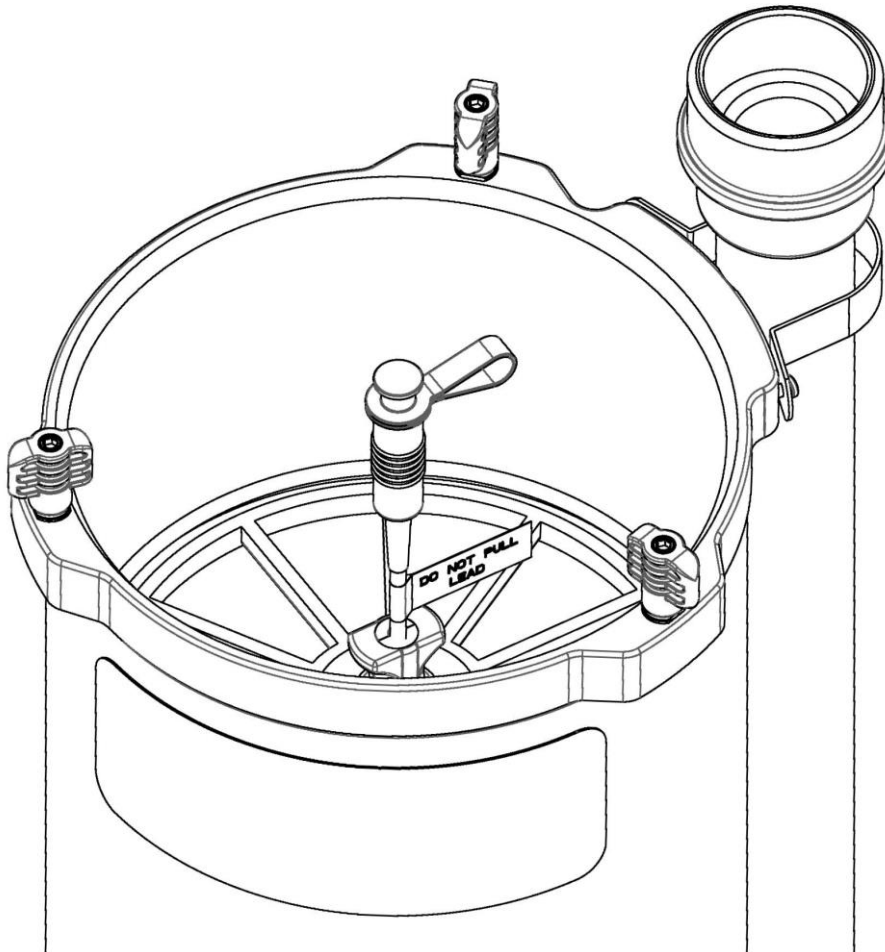

5. Assemble the lid into the canister and complete the rebreather setup as normal including all the pre-dive checks.

Pre-Dive Operation

Connection tests are done on switch on and ticks are displayed to show the device is connected.

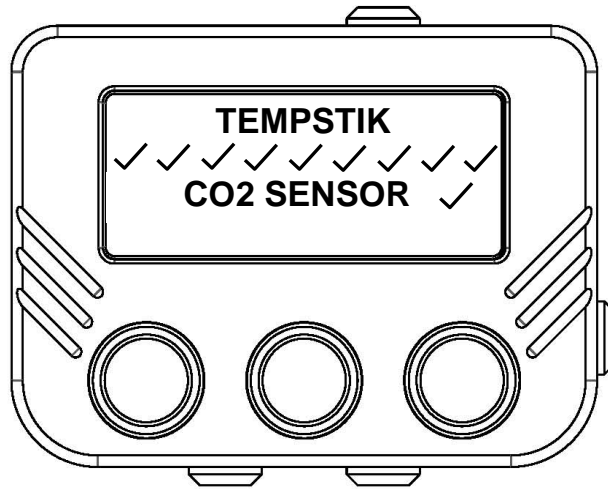

If the Temp-Stik is not detected a row of crosses are displayed:

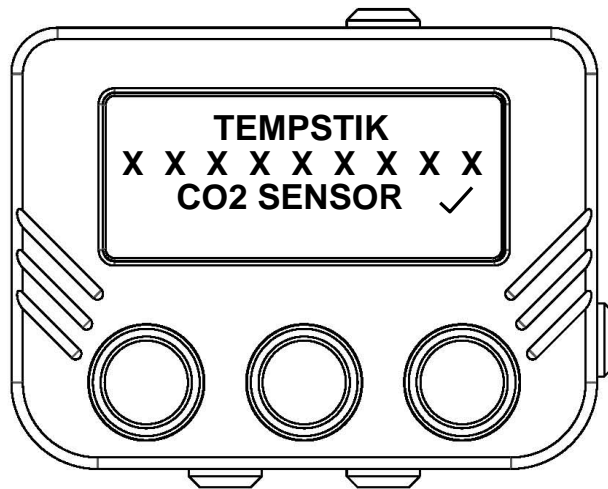

However, should the CO₂ sensor not be detected, the CO₂ sensor is simply not shown:

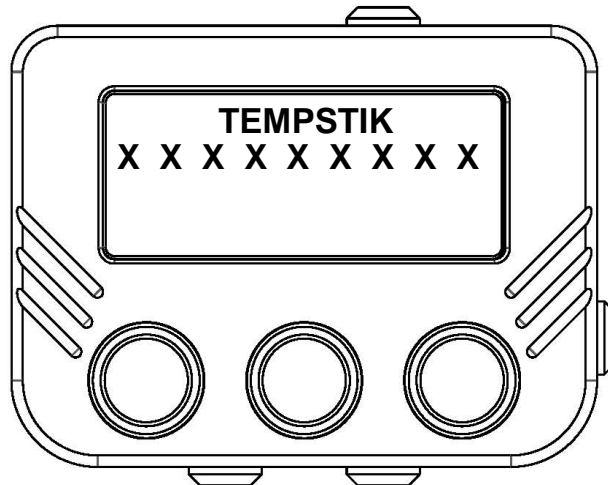

If the CO₂ Sensor is not fitted or connected properly, the sensor will not be listed. If the device should be connected, check that the Fischer connectors are correctly mated and restart the rebreather to confirm.

Dive Mode Operation

The CO₂ sensor is zeroed during calibration of the O₂ Sensors in order to give accurate readings. For this reason, it is paramount that the rebreather is calibrated before every dive when using the CO₂ Sensor.

If the CO₂ sensor is used alone, not with a Temp-Stik, when in dive mode the handset will display four + symbols in the centre of the top row to indicate that the CO₂ Sensor is connected and operational.

Note: if the Temp-Stik is fitted then the normal scrubber mimic is shown in place of the crosses.

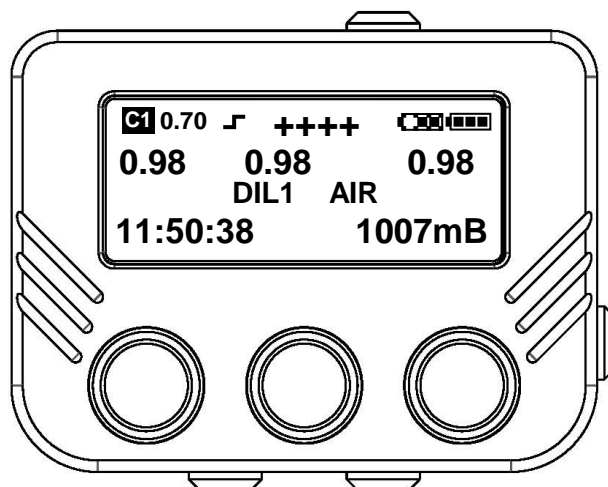

If a Scrubber Monitor is also connected, the scrubber gauge will be shown as standard, but the 4 + symbols can be seen by pressing and holding the left button for 2 seconds. Before entering the water check that the CO₂ Sensor is present and operational. There is no actual mbar reading for current ppCO₂ as we would expect this to be 0 for the majority of dives and would take up valuable display area. The other reason of course is: when breathing elevated levels of CO₂ it is not the time to be self-determining what level of CO₂ is safe for you. A significant proportion of people are CO₂ retainers and accept higher levels of CO₂, right up until they go unconscious.

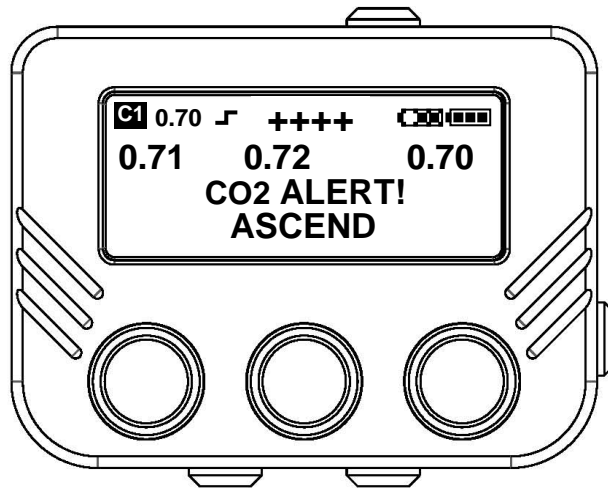

The CO₂ Sensor will trigger an alarm when CO₂ reaches 5mbar in the breathing loop. The display will show “CO₂ ALERT! ASCEND”. This will cycle with any other warnings that might be present. The warning will also be shown on the Vision HUD, whilst the buzzer sounds. The HUD will show solid red lights on both controllers for the period that the CO₂ is above 5mbar.

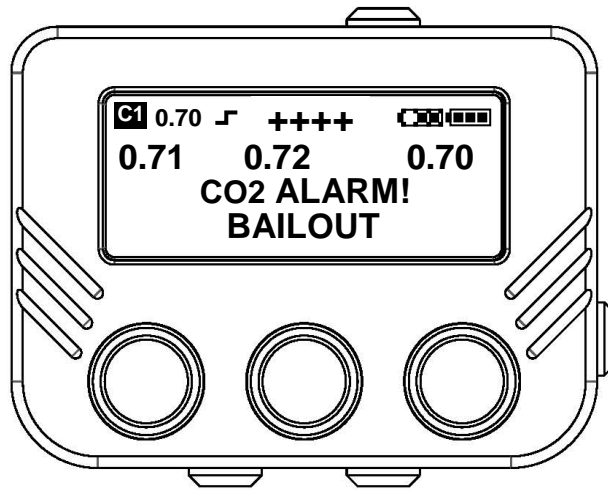

The CO₂ Sensor will trigger an alarm when CO₂ reaches 10 mbar in the breathing loop. The display will show “CO₂ ALARM! BAILOUT”. This will cycle with any other warnings that might be present. The warning will also be shown on the Vision HUD, whilst the buzzer sounds. The HUD will show solid red lights on both controllers for the period that the CO₂ is above 5mbar.

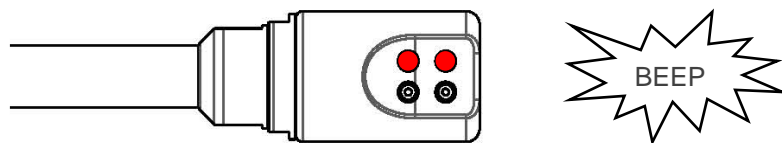

Recognised research into the effects of CO₂ and the EN14143 rebreather standard suggest that the 5mbar warning level is suitable to allow the diver to react in an appropriate manner, before CO₂ gets too high. This could be reducing work rate, ascending, completing the dive as quickly and safely as possible or bailing out from the rebreather. Reducing depth can lower the CO₂ content of the loop enough to cause the CO₂ alarm to stop for a short period

Once an alarm is triggered, the CO₂ content will continue to rise, unless action is taken and depending on the conditions it can rise very quickly. At 5mbar CO₂ there might not be recognisable symptoms of the effect of CO₂ but it will not be long before the levels are very dangerous, so do not ignore a warning. Elevated levels of CO₂ can cause the diver to become unconscious.

In The Event of a Warning

DO:

- Reduce depth
- Lower work rate
- Pay particular attention to the potential onset of CO₂ symptoms
- Consider bailing out from the rebreather if the situation is suitable

DO NOT:

- DO NOT Ignore a CO₂ Sensor warning
- DO NOT Increase depth
- DO NOT Increase work rate
- DO NOT use the CO₂ sensor without the screw-on protector fitted.

DiveStore and PC Connection

The bridge interface, supplied with every Vision rebreather, is used to download dive information from the rebreather, to upload new firmware to the rebreather and to upload new system keys which alter the functionality or customer details stored on the rebreather. When using the bridge interface it must be connected directly to the rebreather lid, not to the CO₂ sensor.

The DiveStore is used for downloading dives from the rebreather and storing them so they can be transferred later to a PC. The DiveStore must be connected directly to the rebreather lid, not to the CO₂ sensor.

Note: Do not connect the DiveStore or the PC Bridge Interface to the CO₂ sensor.

Dive Log / Log Viewer

When viewing your dive downloads in APD LogViewer, Version 5.0.4.3 onwards, any CO₂ warnings given during the dive are shown in the bottom left in red as you scroll through the dive.

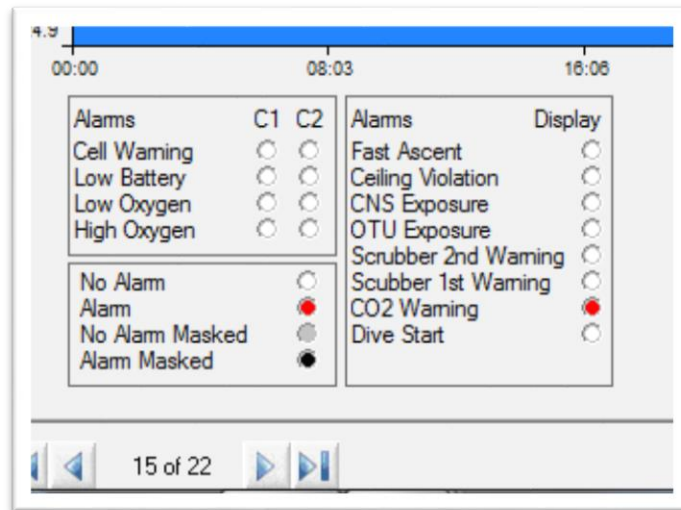

Maintenance

As you know from your rebreather training, Sofnolime should be replaced at regular intervals. It is important that you don't simply dive until you hear the CO₂ sensor warning. The CO₂ sensor does not predict absorbent duration, it simply reacts to the CO₂ level within the scrubber lid area. If you are given a CO₂ sensor warning, fresh Sofnolime and protector must be used for any subsequent dives. If the CO₂ Sensor is left exposed to high concentrations of CO₂, then a short period of recovery may be required. If you wish to reuse a sensor quickly after a dive that resulted in a CO₂ Sensor warning, remove the sensor from the rebreather and allow it to sit in fresh air for at least 5 minutes before assembling with a new protector, calibrating and diving.

Post dive, always store the sensor with a CO₂ Sensor Protector assembled onto it as protection. Store in a clean dry environment and take care not to damage the Sensor face itself or leave this exposed. Use the protective rubber covers to seal the Fischer connectors when not in use. Do not leave the CO₂ Sensor inside the breathing loop when performing cleaning and disinfecting regimes.

Before use you should make sure that the sensor face is free from moisture as this can affect the sensors accuracy in use. You should also check that Fischer connector contacts are clean and dry before assembling into the unit.

AP Diving recommend that the protector is changed every 20-30 hours. This expected duration can vary due to the particular diving conditions that can alter the amount of water vapour present in the breathing loop as well as the humidity the protector is stored in. Use the elapsed timer feature to monitor the time in which the protector has been exposed to moisture and change within these time frames to avoid false alarms.

Keep new protectors in the sealed packaging until required for use.

Manufacturer

Designed and Manufactured in the UK by:



Ambient Pressure Diving Ltd
Unit 2C, Water-ma-Trout Industrial Estate,
Helston, Cornwall. TR13 0LW.
Telephone: +44 (0)1326 563834
FAX: +44 (0)1326 573605
www.apdiving.com

For spares and accessories visit:
www.apdivingdirect.com

EC TYPE Approval

EC Type approved by SGS United Kingdom Ltd, Unit 202b, Worle Parkway, Western-Super-Mare, Somerset, BA22 6WA. Notified Body number 0120.

The “Inspiration”, “Evolution” and “Evolution+” [with CO₂ Sensor] are CE approved to 40m using an air diluent and 100m using a Heliox or Trimix (with a max. END of 30m at 70m, reducing to an END of 24m at 100m). The EC Type Approval was granted on the APD Manufacturer’s Technical Specification and satisfactory user trials. The Technical Specification was based on the “Respiratory equipment-Self-contained re-breathing diving apparatus” standard EN14143:2013 specifically clauses 5.9.4 Active warning devices (in relation to the CO₂ Sensor).

EC PPE Article 11B Approval

The on-going certification to allow CE marking under Article 11B Directive 89/686/EEC is granted by Lloyd’s Register Quality Assurance Ltd. CE0088.