



3rd generation Inspiration Solenoid Maintenance Manual

Version 2.00
May 2017
Written by Tino de Rijk

Table of Contents

1. Introduction	3
1.1 Servicing	3
1.2 Warranty	3
1.3 Copyright and Applicable Law	3
2. Solenoid Exploded Diagram and Parts List	4
2.1 Solenoid main assembly	4
3. Service Kit Contents (RB06/01/12B/SKIT) and Tools	5
3.1 Two models, same solenoid	5
3.2 Service Kit Contents	5
3.3 Tools Needed	7
4. Disassembly Instructions	8
4.1 Preparation: Remove the scrubber lid from the rebreather	8
4.2 Remove the 1-inch nut that holds the oxygen hose attachment onto the scrubber lid	8
4.3 Remove the spiderplate	9
4.4 Lift the oxygen hose attachment with solenoid from the scrubber lid	9
4.5 Unscrew the oxygen hose attachment from the solenoid head	10
4.6 Remove the mesh filter and O-ring from the oxygen hose attachment inlet	11
4.7 Remove the circlip from the solenoid piston housing	12
4.8 Unscrew the outlet restrictor from the solenoid head	12
4.9 Unscrew the solenoid piston housing from the solenoid head	13
4.10 Inspect the sealing surface of the solenoid piston for any damage	14
4.11 End of the disassembly phase	15
5. Clean and Replace Service Parts	16
5.1 Service kit contents	16
5.2 Special attention items during inspection	17
5.3 Ultrasonically clean deposits from all metal parts	17
5.4 Replace all O-rings with new ones from the Service Kit	17
5.5 How to lightly grease O-rings	18
6. Assembly Instructions	20
6.1 Screw the solenoid piston housing into the solenoid head	20
6.2 Screw the outlet restrictor into the solenoid head	21
6.3 Refit the circlip onto the solenoid piston housing	23
6.4 Fit a new mesh filter and new O-rings to the oxygen hose attachment	23
6.5 Screw the oxygen hose attachment back into solenoid head	25
6.6 Refit the oxygen hose attachment with attached solenoid back onto the scrubber lid	25
6.7 Refit the 1-inch nut that holds the oxygen hose attachment onto the scrubber lid	26
6.8 Refit the spiderplate onto the scrubber lid	28
6.9 Place the scrubber lid back into the Inspiration rebreather	28
7. Testing Instructions	29
7.1 Test for leaks without switching on the rebreather electronics	29
7.2 Test for proper operation and leaks with switched on rebreather electronics	29

1. Introduction

1.1 Servicing

Before servicing this solenoid, you must receive instruction and certification in the maintenance of this solenoid by AP Diving Ltd. Without the correct training it is possible to configure the solenoid incorrectly in an unsafe manner.

Factory or Dealer prescribed service for this solenoid recommended at least once annually.

The Inspiration, Evolution and Evolution+ closed circuit rebreathers' CE certification to EN14143 is unaffected by the replacement of a previous type solenoid by this newer version.

This solenoid meets the requirements of the Personal Protective Equipment Directive 89/686/EEC – CE certification when fitted an AP Diving rebreather.



WARNING: when servicing the solenoid, it is VERY important that all parts that may suffer wear and tear get replaced. It is also very important that the correct tools are used to avoid damaging any part of the solenoid in the disassembly and assembly process. Please don't try to save money by re-using parts that really should be replaced during a proper servicing action.

 The numbers between brackets after the part names in the disassembly and assembly chapters correspond to the sequence numbers in the diagrams in chapter 2.

1.2 Warranty

This solenoid is covered by AP's 1-year warranty against defects in materials or workmanship. This warranty is only extended to the original purchaser, and is not transferable. For more information, be sure to read the warranty section of the user manual, and the purchaser should save the sales receipt.

A copy of the receipt must be presented whenever obtaining warranty service.

1.3 Copyright and Applicable Law

This Maintenance Manual is copyrighted, all rights reserved. It may not, in whole or in part, be copied, photocopied, reproduced, translated, or reduced to any electronic medium (including the Internet) or machine-readable form without prior consent in writing from AP Diving Ltd.

All products are sold on the strict understanding that only English Law applies in cases of warranty claims and product liability, regardless of where the equipment is purchased or used. Should a claim be made then the venue for this would be in Truro, England.

© 2017 AP Diving Ltd.

Inspiration 3rd generation Inspiration Solenoid Maintenance Manual

2. Solenoid Exploded Diagram and Parts List

2.1 Solenoid main assembly

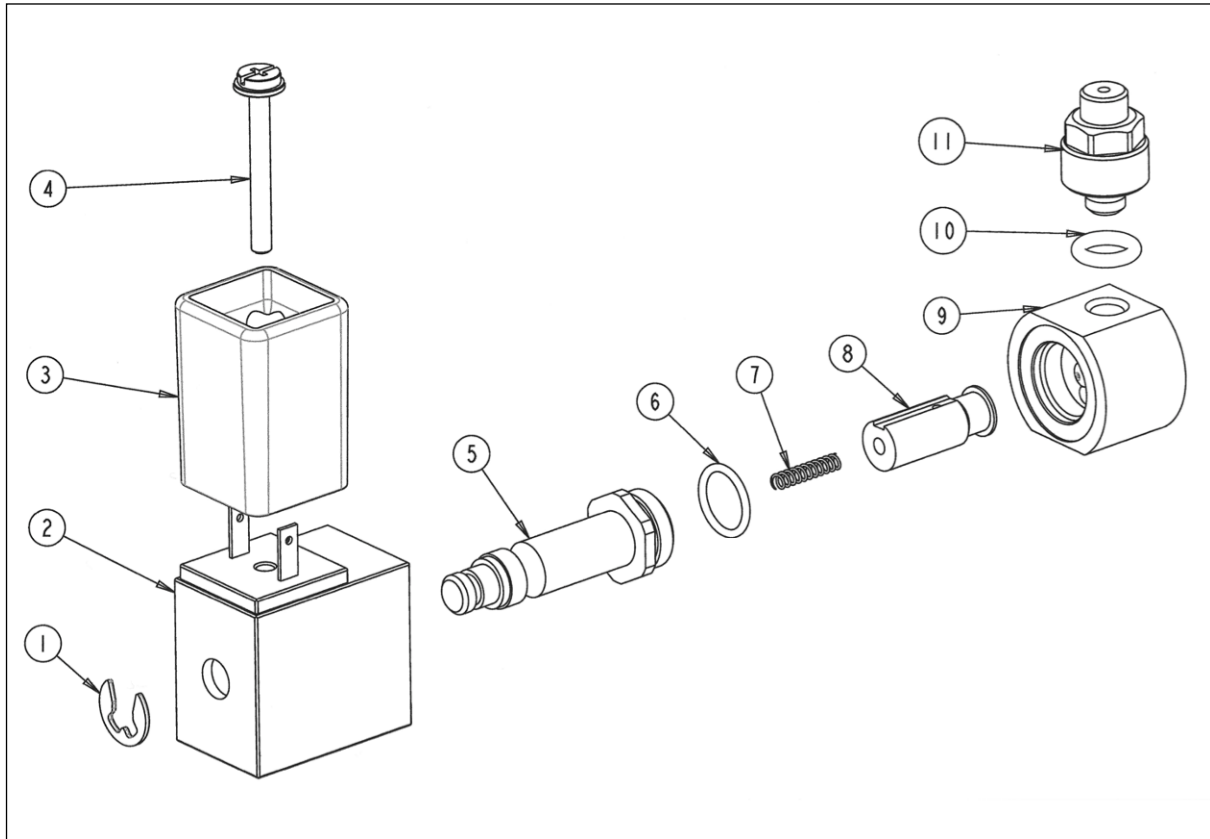

NUMBER	DESCRIPTION	PART NUMBER	QUANTITY
1	E-clip	SC_302	1
2	Solenoid coil housing	RB_06_01_12_1	1
3	Solenoid potting housing	RB_06_01_12_7	1
4	M2.5 x 22mm screw	SC_121	1
5	Solenoid piston housing	RB_06_01_12_2	1
6	Solenoid O-ring	OR7 x 1 V75	1
7	Solenoid piston spring	RB_06_01_12_3	1
8	Solenoid piston	RB_06_01_12_4	1
9	Solenoid head	RB_06_01_16A	1
10	BS-009-N70 O-ring	BS_009_N70	1
11	Outlet restrictor	EV_06_01_16	1

3. Service Kit Contents (RB06/01/12B/SKIT) and Tools

3.1 Two models, same solenoid

The 3rd generation solenoid from AP Diving can be found in the field in two versions:

- A version with a rounded steel solenoid head (used between 3-2011 and 3-2012), and
- A version with a square steel solenoid head (used after 3-2012).

The picture below shows both versions side by side:

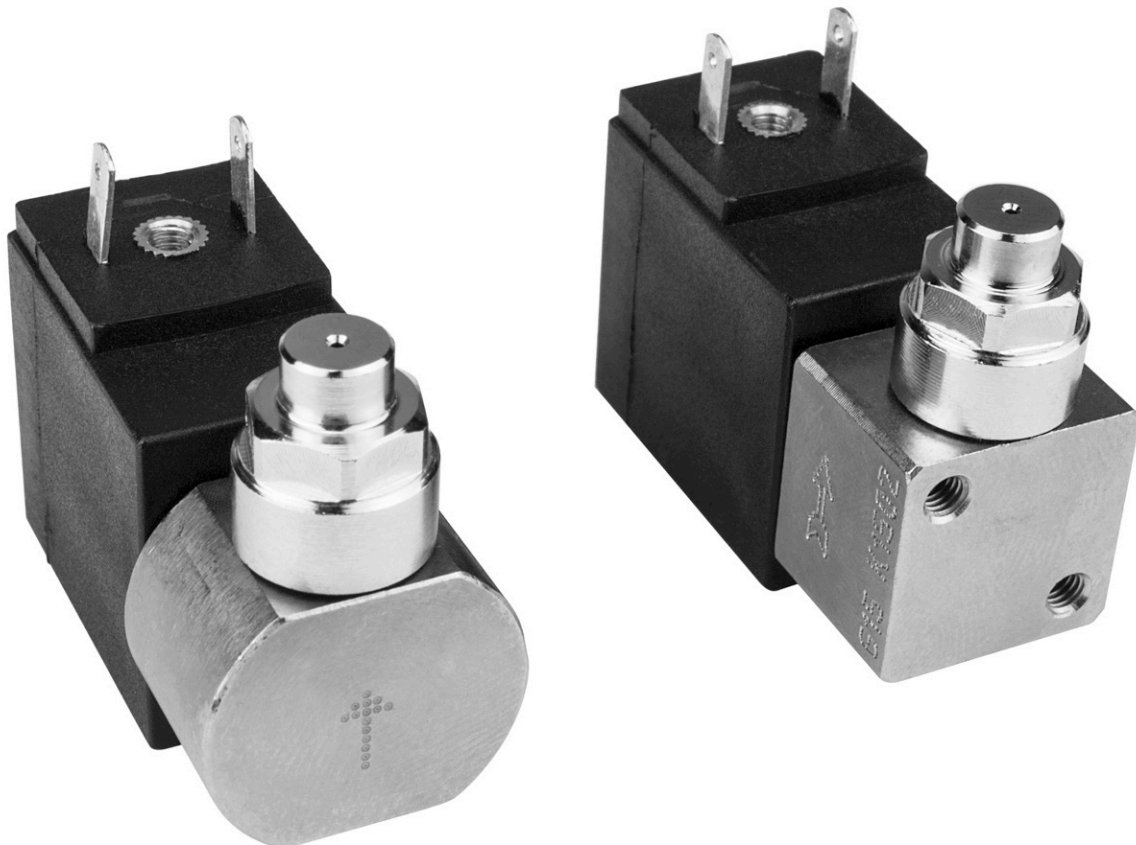

PLEASE NOTE: Apart from the shape of the head and the position of the flow-direction arrow, both solenoids are identical. As such, the servicing instructions in this manual can be applied exactly the same to both models.

3.2 Service Kit Contents

⚠ WARNING: When replacing O-rings, next to the size, the hardness of the O-rings (declared in degrees Shore, and indicated by the suffixes N70 and N90) is **ESSENTIAL** for proper operation. AP Diving deliberately chooses the N70 hardness of the O-rings for the solenoid.

If, against our recommendation, you choose to select your O-rings to come from another source than AP Diving Ltd., make sure you select the right type in size **AND** hardness (degrees Shore) **AND** material (composition).

When servicing the solenoid, the following parts need to be replaced:

NUMBER	DESCRIPTION	PART NUMBER	QUANTITY
1	Solenoid O-ring: fitting on solenoid piston housing	OR7 x 1 V75	1
2	BS-009-N70 O-ring: 1 fitting on the outlet restrictor and 1 fitting on the oxygen hose attachment outlet	BS_009_N70	2
3	BS-022-N70 O-ring: Both fitting on the oxygen hose attachment	BS_022_N70	2
4	BS-010-N70 O-ring: fitting on O2 MP hose going into the oxygen hose attachment	BS_010_N70	1
5	Mesh filter to go inside the inlet of the oxygen hose attachment	EV06/01/14A	1

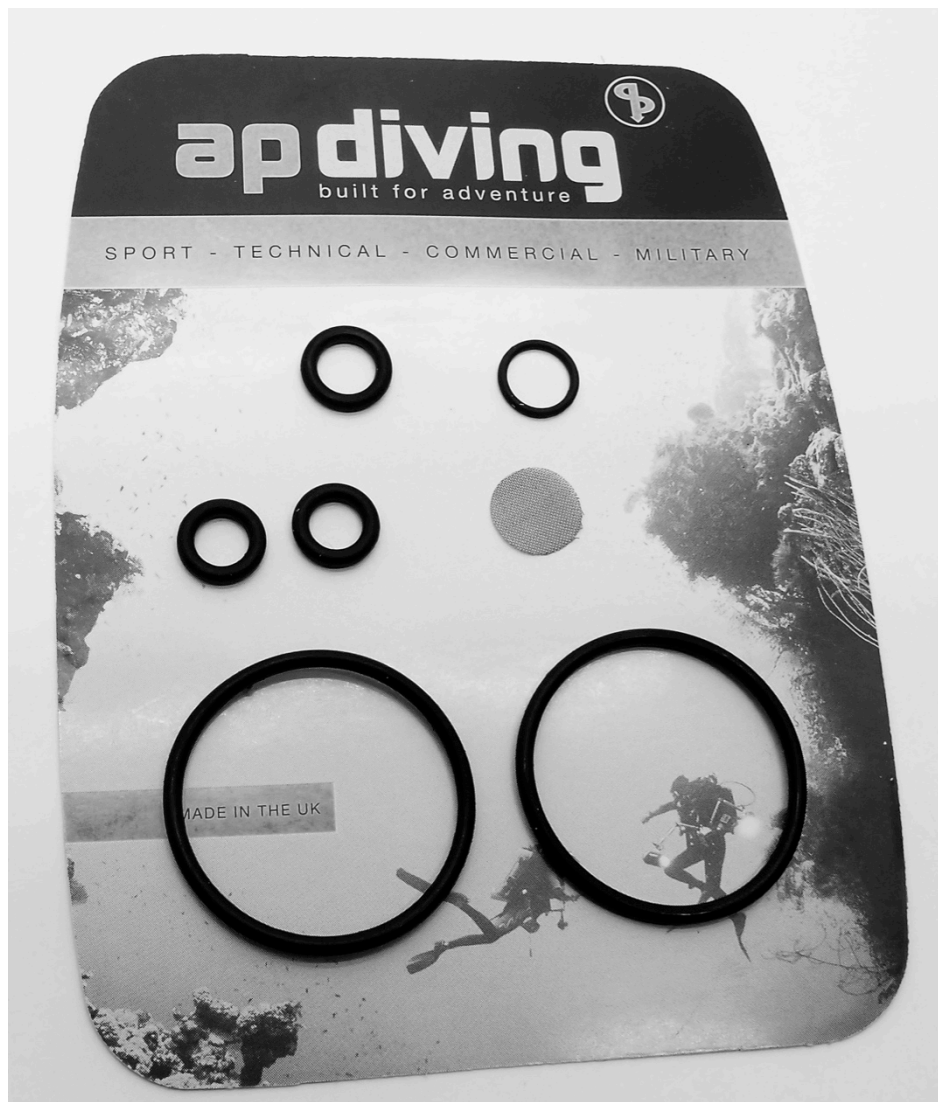

3.3 Tools Needed

There are no special tools needed for servicing the 3rd generation Inspiration solenoid.

Normal tools needed are:

- 9 mm, 11 mm and 1 inch wrenches;
- Various small screwdrivers;
- Oxygen-compatible grease;
- (Access to) an ultrasonic bath for cleaning the metal parts.



WARNING: Do NOT use aggressive chemicals. They might damage the metal coating of the solenoid. Use an ultrasonic cleaning bath with a suitable cleaning fluid. A very good cleaning fluid is Biox "O2" immersion fluid. See WWW.BIOXINT.COM for further information and distributors.

The use of rubber gloves while re-assembling the solenoid is mandatory to avoid rendering the solenoid oxygen unclean due to human touch.

4. Disassembly Instructions

4.1 Preparation: Remove the scrubber lid from the rebreather

- In order to be able to properly service the solenoid, it is necessary to remove the scrubber lid from the rebreather for easy access to the solenoid during maintenance.
 - o Remove the medium pressure (MP) O₂ hose, coming from the O₂ 1st stage of gas distribution bar (depending on the model rebreather).
 - o Remove the corrugated inhale hose that goes from the centre of the scrubber lid to the inhale T-piece.
 - o Lift the scrubber lid from the rebreather, obviously with the hoses to the handset and buzzer still in place.
- Leave the spiderplate in place for now for protection during transport to your workbench.

4.2 Remove the 1-inch nut that holds the oxygen hose attachment onto the scrubber lid

- Use a proper size wrench. The correct size is 1 inch (i.e. non-metric), not 26 mm.
- Remove the BS-022-N70 O-ring within the backside of the nut.

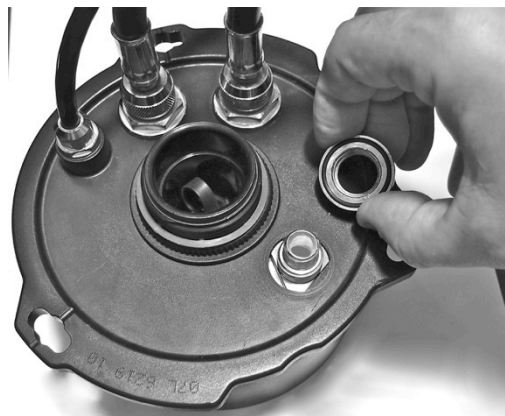

- Clean the surface of the scrubber lid with a soft clean lint-free cloth, and carefully inspect for any damage to the area where the O-ring seals.

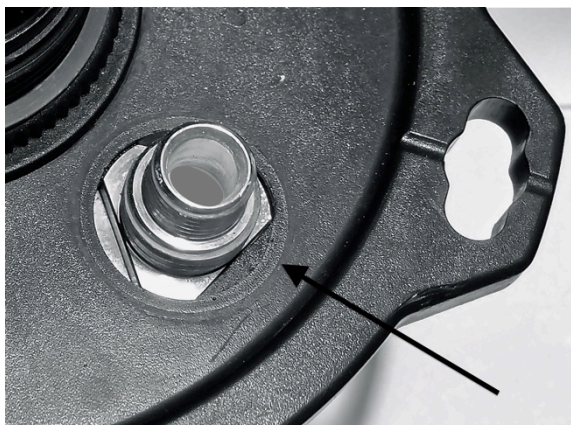

4.3 Remove the spiderplate

- Unscrew the large plastic nut that sits on the inhale tube and fixes the spiderplate to the inhale tube.

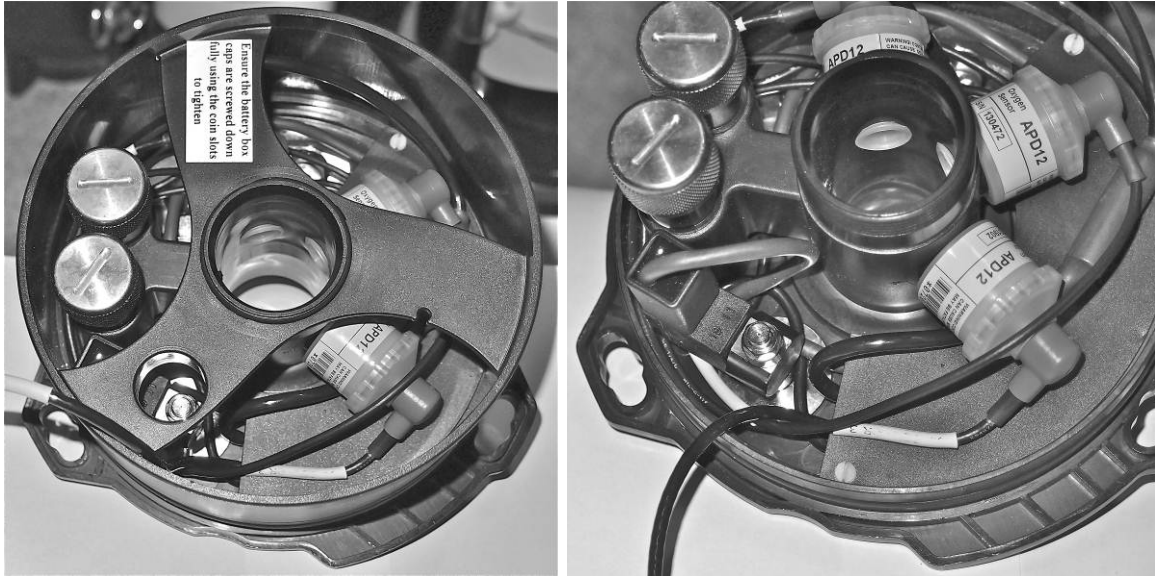

4.4 Lift the oxygen hose attachment with solenoid from the scrubber lid

- **!** **WARNING:** Leave the electrical power cable that connects the black plastic solenoid coil housing and attached potting housing to the switch block under the battery box in place, i.e. do **NOT** attempt to remove or disconnect or unsolder this cable.
 - o There is no need to remove the power cable for normal maintenance, as they do not contain any moving parts or O-rings. Removing it would require removing and later on replacing the potting and the soldered connections inside the potting housing.
 - o Soldering is a delicate job to be left to the factory, as it requires special care, given the high O₂ environment during normal operation of the rebreather.
 - o The potting used inside the solenoid potting housing should ensure that the electrical connections do not get corroded, as they seal the connections against any water ingress, eliminating the need for servicing this particular part.

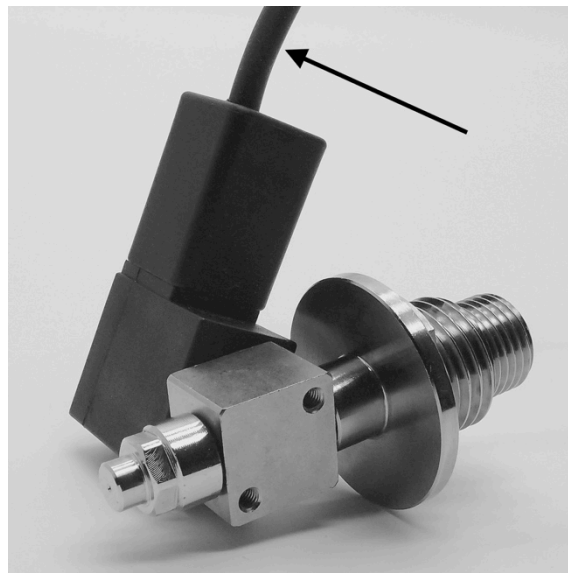

4.5 Unscrew the oxygen hose attachment from the solenoid head.

- Unscrew the oxygen hose attachment from the solenoid head.



- Remove the small BS-009-N70 O-ring from the outlet of the oxygen hose attachment.



4.6 Remove the mesh filter and O-ring from the oxygen hose attachment inlet.

- Using a bent paperclip, push out the old mesh filter from the inside of the oxygen attachment inlet.
- Inspect the old mesh filter for rust or rubber particles etc. Seeing any of these symptoms could be an indicator of corrosion in the O2 cylinder or worn-out MP O2 hoses.
- Always fit a new mesh filter from the service kit.

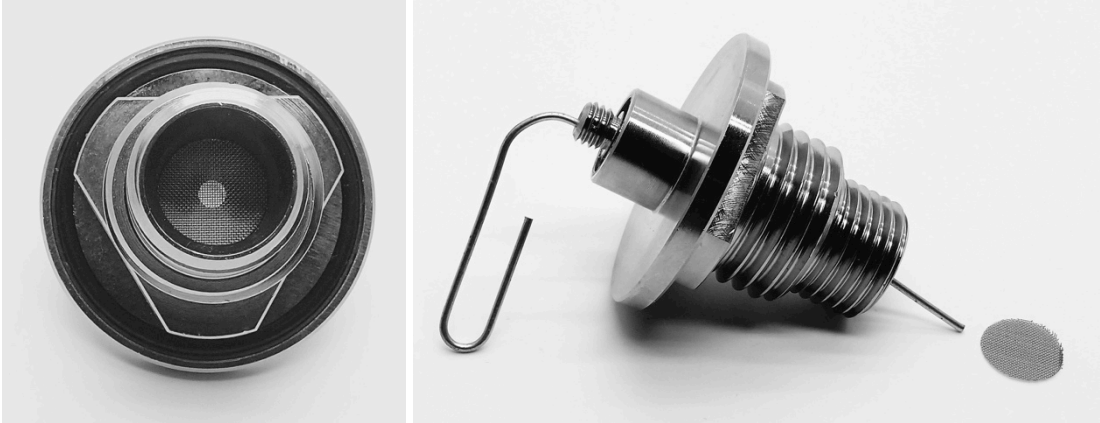

- Remove the large BS-022-N70 O-ring from the backside of the oxygen hose attachment.



4.7 Remove the circlip from the solenoid piston housing.

- The piston housing sticks through the coil housing, and is locked to it with a small circlip.
- Using a small screwdriver, carefully pry off the small circlip.

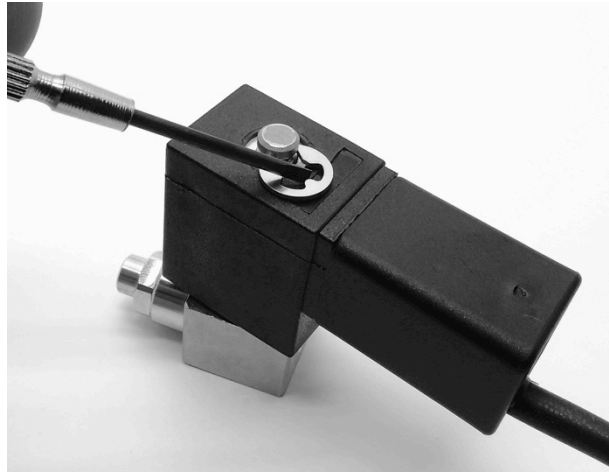

4.8 Unscrew the outlet restrictor from the solenoid head

- Use a 9 mm wrench to remove the outlet restrictor from the solenoid head.



- Remove the small BS-009-N70 O-ring from the outlet restrictor.



4.9 Unscrew the solenoid piston housing from the solenoid head

- Use an 11 mm wrench to remove the solenoid piston housing from the solenoid head.



- Once unscrewed, carefully let the 2 small inner parts drop out, taking special care you do NOT lose the small spring. The two parts coming out are:
 - o The very small solenoid piston spring;
 - o The solenoid piston itself.

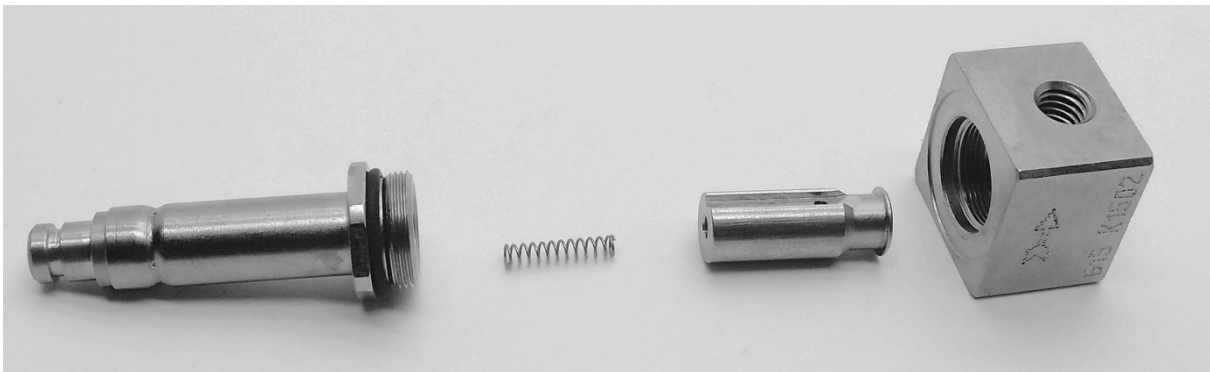

- Next, remove the thin O-ring from the solenoid housing.



4.10 Inspect the sealing surface of the solenoid piston for any damage

- The sealing surface of the piston must be without any damage or dirt. If it is damaged, it MUST be replaced.



4.11 End of the disassembly phase

- This concludes the end of the disassembly phase. The picture below shows all the parts together after disassembly.

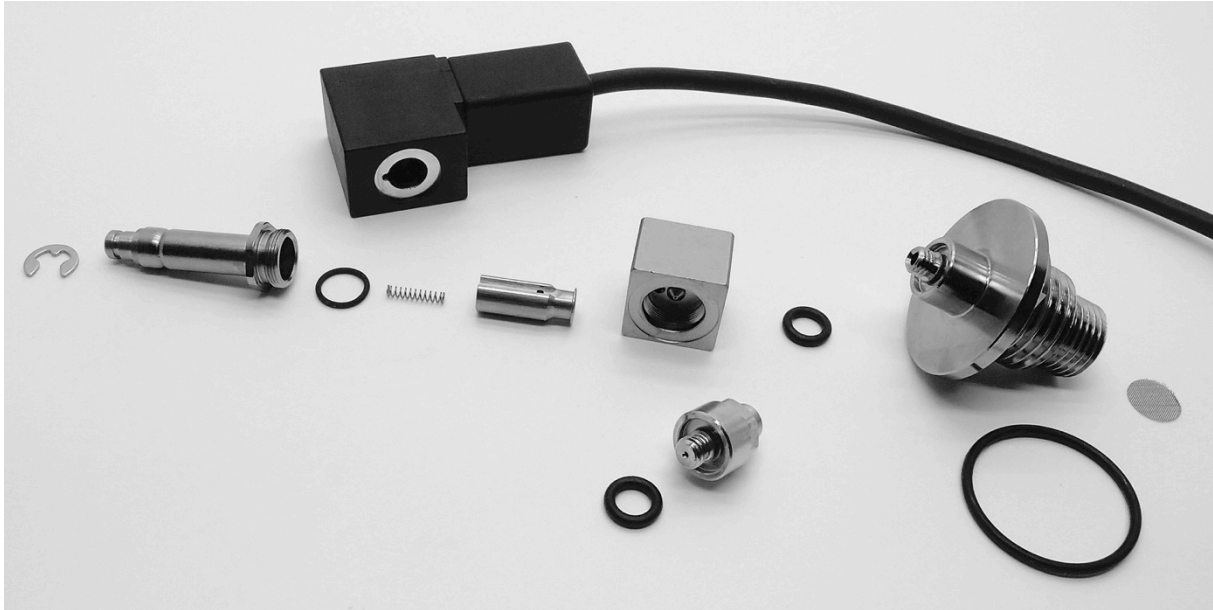

5. Clean and Replace Service Parts

The servicing of the solenoid contains 4 “action groups”:

1. Removing and binning all parts that should be replaced. This includes all O-rings.
2. Depending on the gas content the solenoid is exposed to, keep it in oxygen service.
The CGA (Compressed Gas Association), US Navy, UK’s HSE and the EIGA (European Industrial Gas Association) all recommend that breathing gasses with an oxygen content of 23.5% or higher should be treated as 100% oxygen. However, some technical training agencies still use 40% as the maximum percentage that is allowed for equipment that is not in oxygen service.
AP Diving advises to err on the side of safety, and to use the value of 23.5% as the cutoff percentage beyond which the equipment must be in oxygen service.
If in doubt: keep it in oxygen service, as that only takes a little bit more effort.
 - Obviously, the solenoid **MUST** be kept in oxygen service at all times, as it will be exposed to 100% oxygen during normal use.
3. Ultrasonic-cleaning of all disassembled metal parts. This is mandatory if the solenoid is to be kept in oxygen service, but recommended in all other servicing situations.
4. Lightly grease new parts*, fit them, and re-assemble the solenoid with the correct tools and the correct torques. Use oxygen-compatible grease, and avoid contaminating the metal parts after cleaning. Use the smallest amount of grease possible.



WARNING: *DO NOT GREASE THE PISTON, PISTON SPRING OR INSIDE OF THE PISTON CHAMBER as there is a high risk that this could cause the Solenoid to fail.

The use of rubber gloves while re-assembling the solenoid is mandatory to avoid rendering the solenoid unclean due to human touch.

5.1 Service kit contents

As described in chapter 3.1, the following parts need to be replaced when servicing the solenoid:

NUMBER	DESCRIPTION	PART NUMBER	QUANTITY
1	Solenoid O-ring	OR7 x 1 V75	1
2	BS-009-N70 O-ring	BS_009_N70	2
3	BS-022-N70 O-ring	BS_022_N70	2
4	BS-010-N70 O-ring for O2 MP hose connector	BS_010_N70	1
5	Mesh filter for inlet of oxygen hose attachment	EV06/01/14A	1

5.2 Special attention items during inspection

- Inspect the sealing surface of the solenoid piston for damage and wear
- Inspect the sealing crater inside the solenoid head for damage and wear

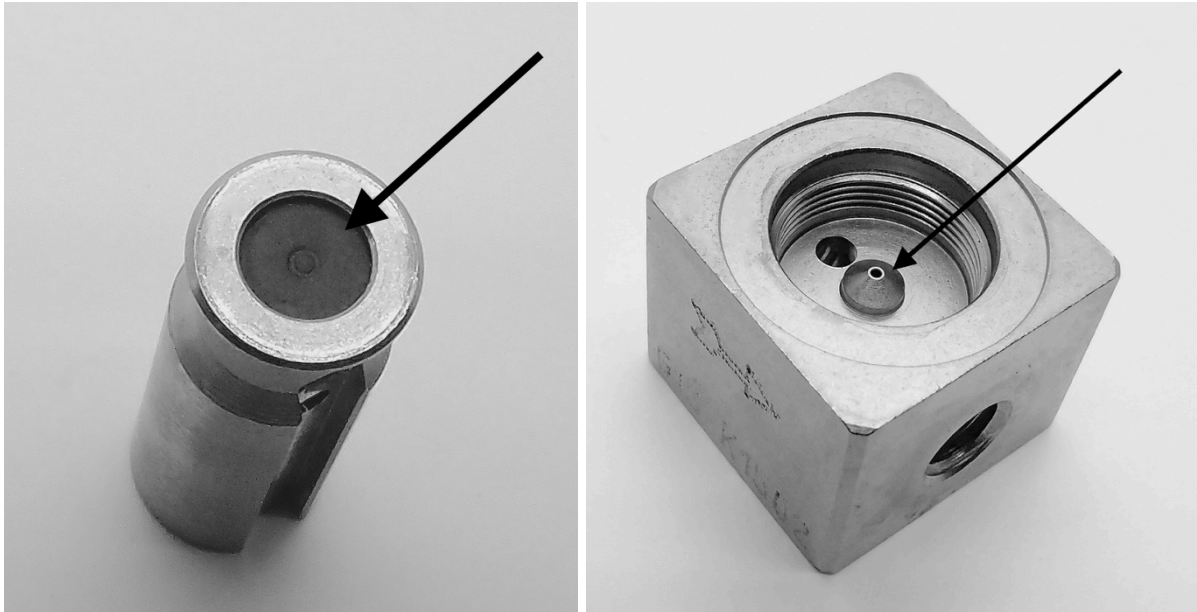

⚠ WARNING: Do NOT expose the combined solenoid coil with its potted-on housing (containing the potted-in electric wire attachments) to chemicals or an ultrasonic bath.

This is a potted, sealed unit that does not require any end-user maintenance, other than some gentle surface cleaning with a clean cloth.

Putting it in an ultrasonic bath could damage the potting and subsequently the wiring.

Moreover, as is extensively explained in paragraph 4.4, in order to be able to put it in an ultrasonic bath you would need to remove (=unsolder) the cable, which is absolutely NOT recommended.

Soldering and crimping the cable is not an end-user recommended activity. It is a sensitive and delicate job, requiring the correct kind of solder, and should as such only be done by the factory.

5.3 Ultrasonically clean deposits from all metal parts

Clean deposits from all metal parts, like chalk and salt.

⚠ WARNING: Do NOT use aggressive chemicals. They might damage the metal coating. Use an ultrasonic cleaning bath with a suitable cleaning fluid instead. A good cleaning fluid is Biox "O2" immersion fluid. See WWW.BIOXINT.COM for further information and distributors.

5.4 Replace all O-rings with new ones from the Service Kit

The part number of the service kit is RB06/01/12B/SKIT. See paragraph 3.1 for contents.

⚠ WARNING:

- Replace all O-rings: do NOT re-use old ones
- ONLY use original parts from APD, to make sure the O-rings:
 - Are the exact size;
 - Are of the correct material (especially important in a 100% O2 overpressure environment);
 - Are of the correct stiffness (degrees Shore).

- Make sure you use only Oxygen-compatible grease, and LIGHTLY grease the O-rings.
- Also make sure you only use Oxygen-clean and Oxygen-compatible replacement parts. All APD-supplied O-rings in the service kit are made from Nitrile and as such are Oxygen compatible. However, they still need to stay or be made Oxygen-clean.
- Last but not least: avoid touching Oxygen-clean parts after cleaning with your bare hands. Human body sweat and grease is not Oxygen-compatible. So use rubber gloves (e.g. surgical) when re-assembling the solenoid.
- For photographic clarity no rubber gloves are worn on the photos in this manual.

5.5 How to lightly grease O-rings

When greasing O-rings, make sure NOT to use too much grease.

Especially O2 compatible grease has the potential to become stiffer over time, which may cause a hardened clot of grease to become a source for leaking.

The best way to grease O-rings is using a simple “grease bag”.

A grease bag is a clean and clear plastic bag, into which you put a small amount of grease. Optionally you can make two bags: one with O2 compatible grease, and one with normal silicone grease. Make sure you label them properly to avoid mixing them up! Also put a date on it, so you know how old your grease bag is. Don't use them longer than a year.

A nice advantage of using a grease bag is that you use only a tiny amount of grease for greasing many O-rings, so there is little waste.

We recommend that you use resealable bags, e.g. the ones with a plastic zipper, typically used for airtight food storage. This allows you to zip up the bag after use, keeping the contents clean for repeated use.

The simple steps are as follows:

- Take a plastic bag and deposit a SMALL amount of grease in it.

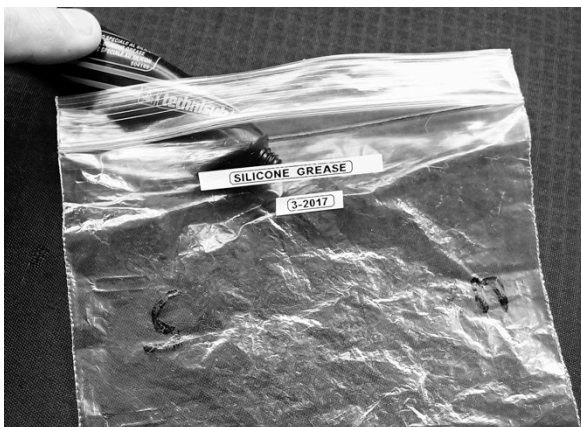

- Massage this grease all around the bag until it is evenly distributed over the inside surface area.
- Take the O-rings to be greased out of their storage container, either using gloves or using an O₂-cleaned instrument like a dentist hook.



- Drop them in the grease bag, and from the outside of the bag move them around with your fingers, making sure they get in full contact with the grease.



- Open the bag, and using a clean instrument like a dentist hook, take the now properly greased O-rings out.
- Inspect them to make absolutely sure that the grease is evenly and lightly distributed on the O-rings and that there are no areas of excess grease - no globs or strands.
- Fit them where they belong on your diving equipment, still making sure not to touch them with your bare hands.

6. Assembly Instructions

⚠ WARNING: When assembling the solenoid, use rubber gloves to avoid polluting it while assembling, rendering it not Oxygen-clean anymore. As this part is exposed to 100% Oxygen under overpressure it MUST stay Oxygen-clean and in Oxygen-service.

⚠ WARNING: DO NOT GREASE THE PISTON, PISTON SPRING OR INSIDE OF THE PISTON CHAMBER as there is a high risk that this could cause the Solenoid to fail.

6.1 Screw the solenoid piston housing into the solenoid head

- Fit a new O-ring onto the solenoid housing.



- Next, carefully refit the 2 inner parts into the piston housing:
 - o Fit the small solenoid piston spring inside the piston, and next
 - o Fit the solenoid piston with spring into the housing, spring first.

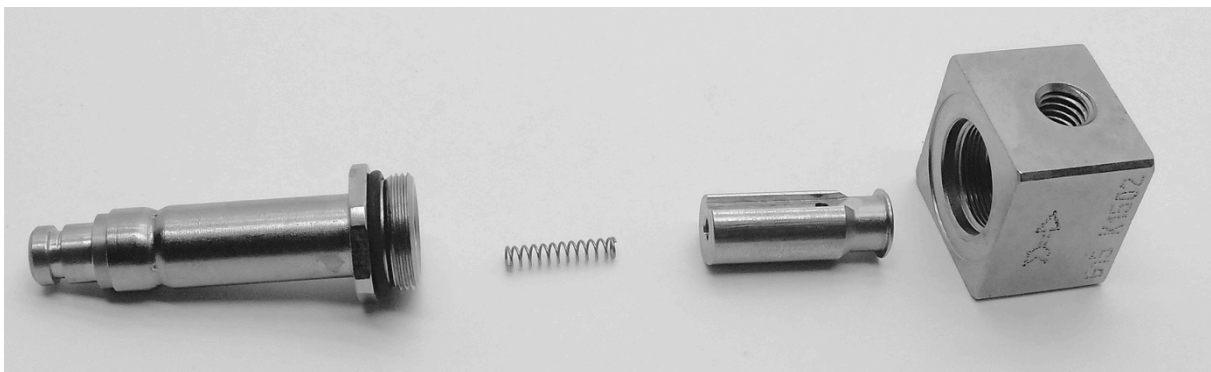



- Use an 11 mm wrench to nip up the piston housing (avoid using force!).

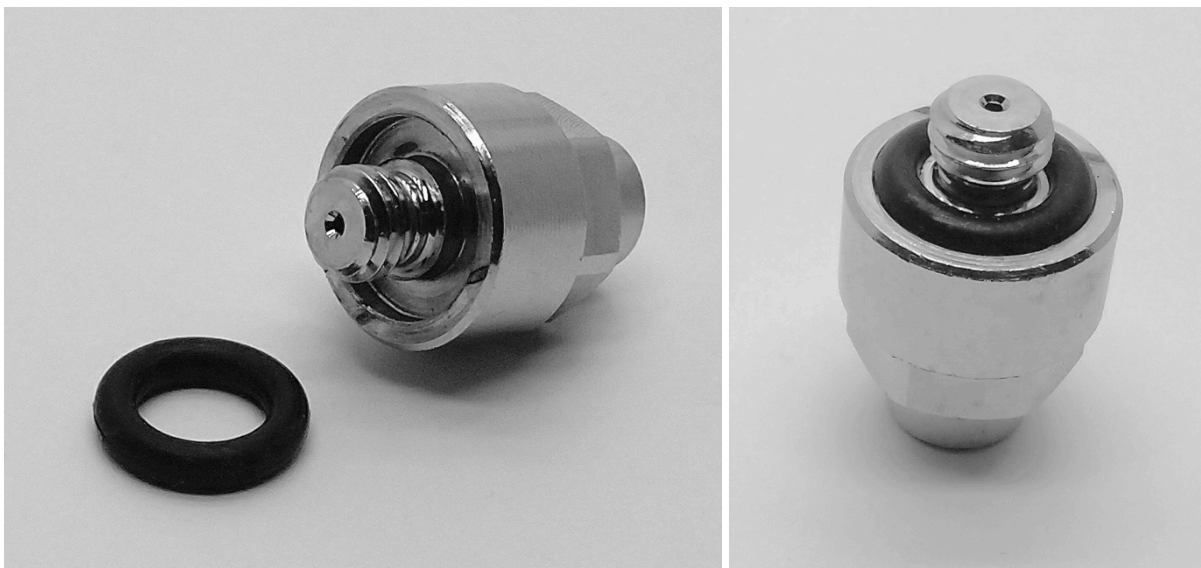

6.2 Screw the outlet restrictor into the solenoid head

- Fit a new BS-009-N70 O-ring to the outlet restrictor.



-  **WARNING:** Fit the outlet restrictor to the correct side of solenoid head. Notice the engraved arrow on the side of the solenoid head. The arrow indicates the direction of the gas flow through the solenoid. The restrictor should be fitted to the pointed side of the arrow, as shown in the picture below.



- Use a 9 mm wrench to nip up the restrictor (avoid using force!).

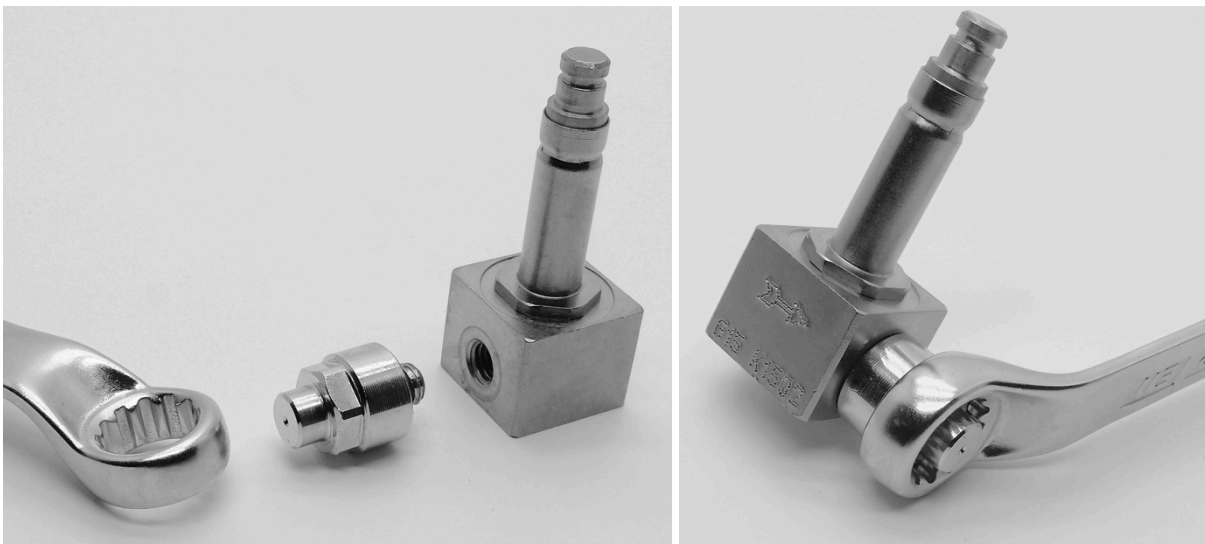

6.3 Refit the circlip onto the solenoid piston housing

- Push the piston housing through the coil housing, so it sticks out at the other end.
 - o The piston can only be fitted in one way, as the holes in the coil housing have different diameters. The piston sticks out of the smaller hole.
- Pry the circlip back onto the piston housing using a small screwdriver and/or tweezers.
- Check to make sure the circlip sits snugly into the recess on top of the piston housing.

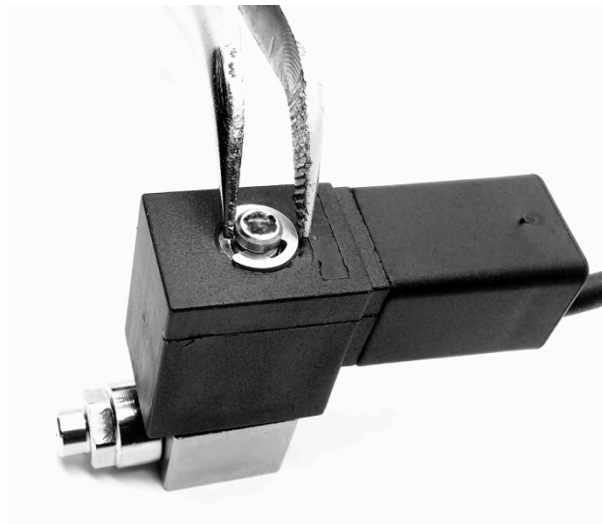
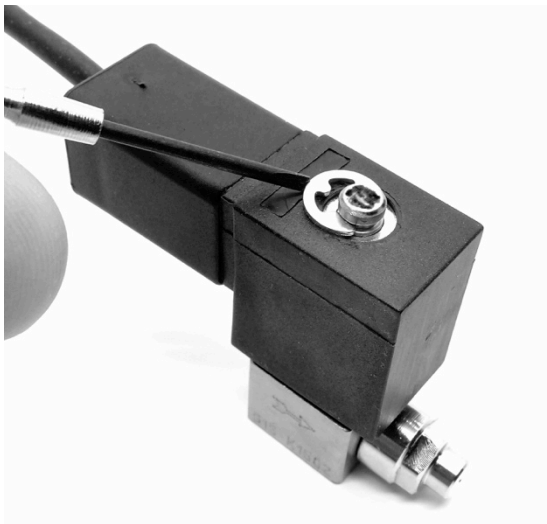
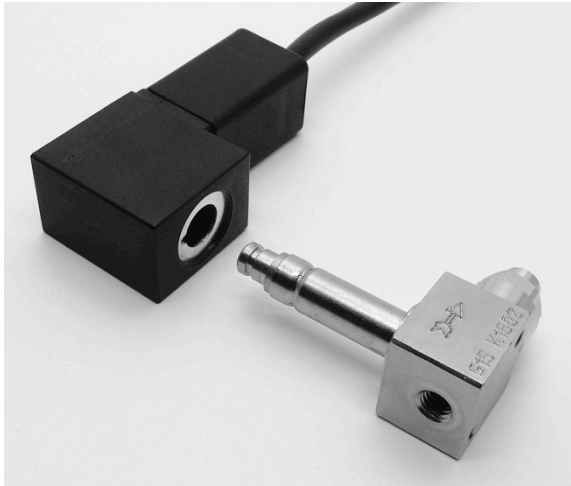

6.4 Fit a new mesh filter and new O-rings to the oxygen hose attachment

- Fit a new mesh filter into the inlet of the oxygen hose attachment.
- Push it very gently into place, using small tweezers or the rubber eraser backside of a wooden pencil, taking care not to damage the mesh filter.

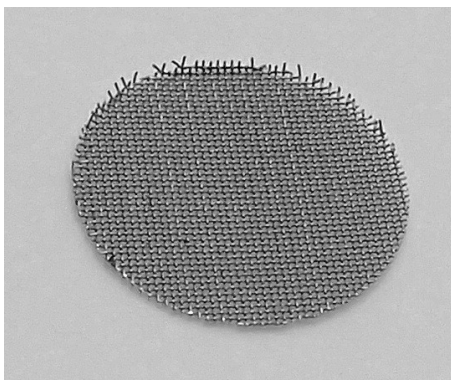

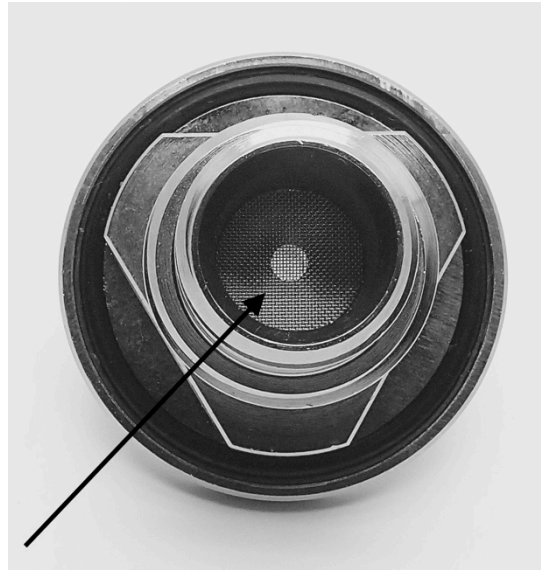

- Fit a new small BS-009-N70 O-ring onto the outlet side of the oxygen hose attachment.

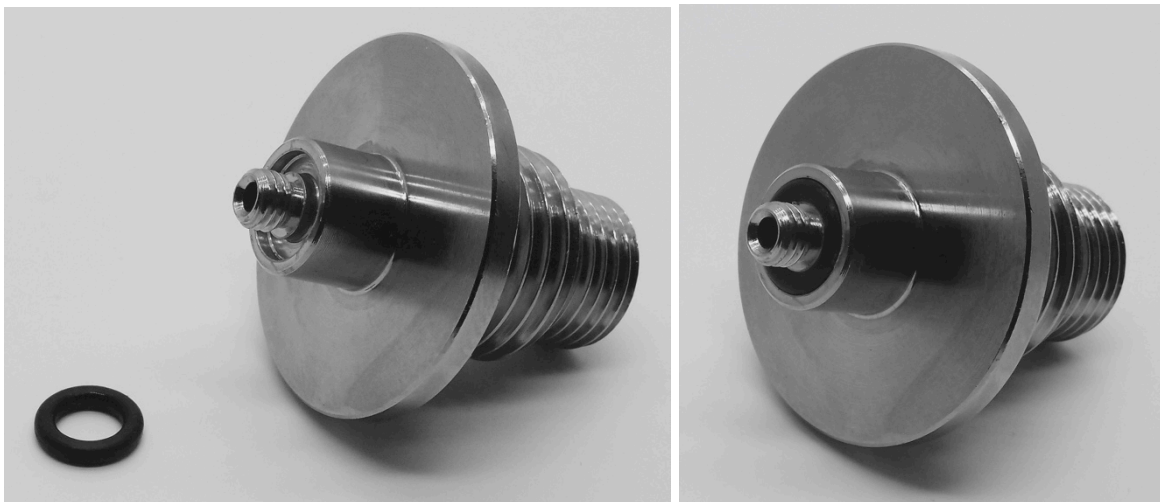

- Fit a new large BS-022-N70 O-ring onto the large inlet side of the oxygen hose attachment.



6.5 Screw the oxygen hose attachment back into solenoid head

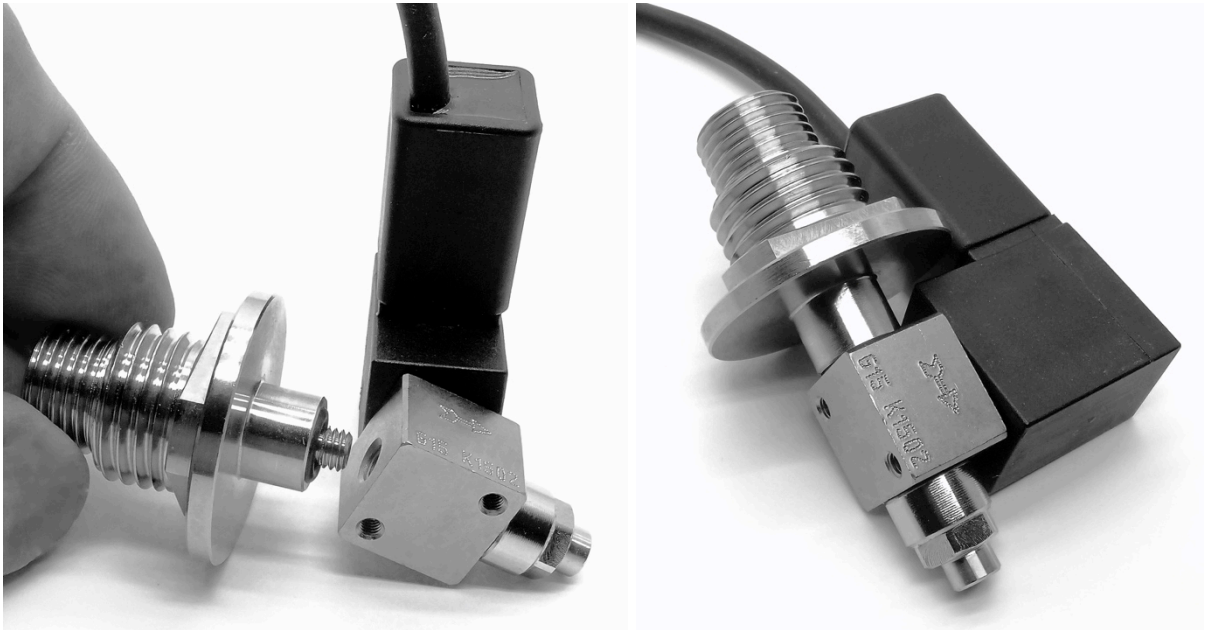

6.6 Refit the oxygen hose attachment with attached solenoid back onto the scrubber lid



-  **WARNING:** Make sure the tabs on the oxygen hose attachment align properly with the hole in the scrubber lid. Make sure one of the three flat sides of the oxygen hose assembly aligns properly with the flat side of the cutout in the opening in the scrubber head. See arrows below, pointing to that flat side.
- If the oxygen hose attachment is NOT properly aligned, the resulting space on the inside of the scrubber lid will cause it not to seal despite the big O-rings on both sides (the one in the oxygen hose attachment, and the one in the 1-inch nut).
- You can position the solenoid assembly in 3 positions (each 120 degrees apart), using one of the three flat sides of it to align with the flat side of the hole in the scrubber lid.
 - o Choose the position that most closely matches the position of the solenoid as shown in the picture above.

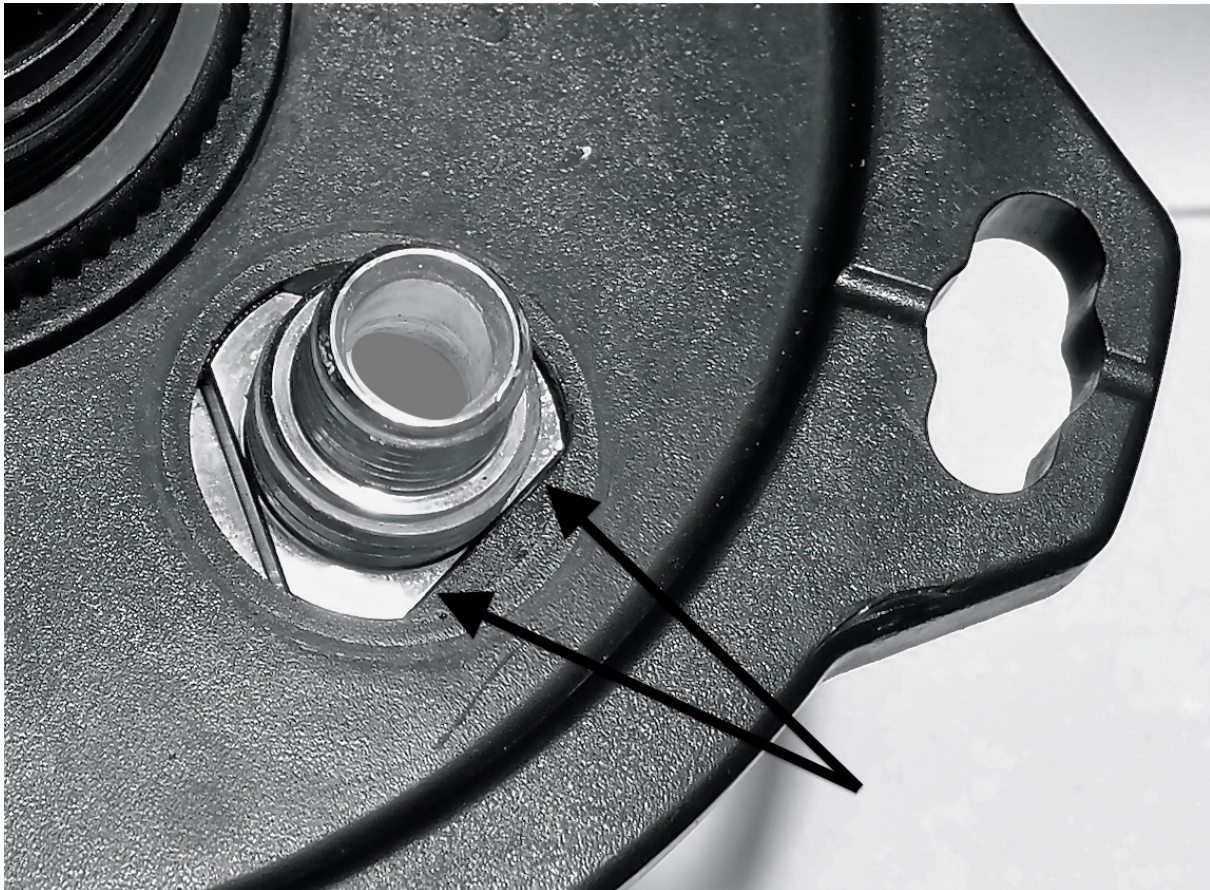

6.7 Refit the 1-inch nut that holds the oxygen hose attachment onto the scrubber lid

- Fit a new BS-02-N70 O-ring onto the backside of the 1-inch nut.



- Check and clean the surface of the scrubber lid where the O-ring on the backside of the 1-inch nut will seal against it.

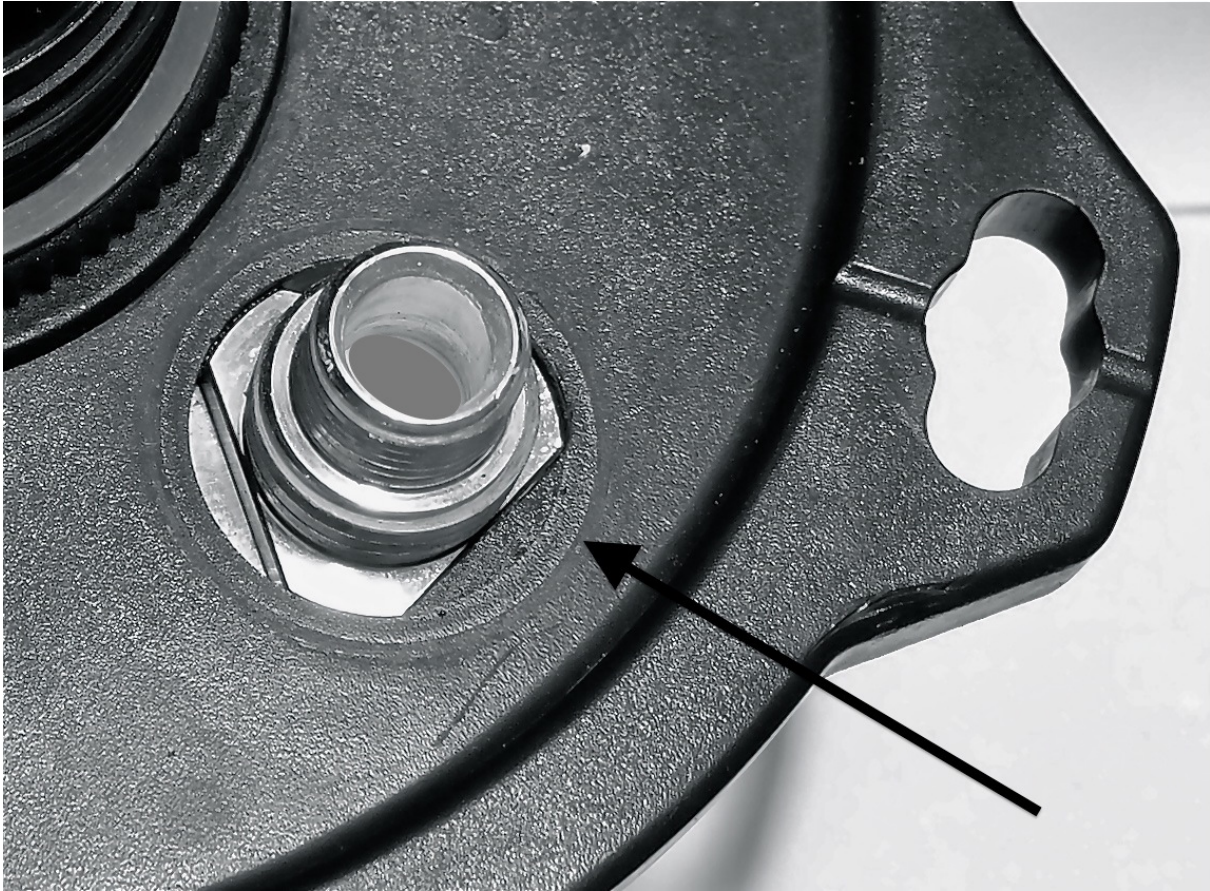

- Gently nip up with a 1-inch wrench. Do NOT use force (as it is the O-ring that seals, not the nut itself). It is very easy to use too much force which such a big size wrench.



6.8 Refit the spiderplate onto the scrubber lid

- Screw the big plastic nut back onto the inhale tube (that is the tube that holds the oxygen cells).
-  **WARNING:** Make sure the little tab on the outside of the inhale tube aligns properly with the recess in the spider plate. If fitted properly, the hole in the spider plate (if present, depending on the age of the spiderplate) should sit on top of the solenoid outlet restrictor, as such not blocking the oxygen injection flow, allowing for proper mixing of oxygen with diluent.

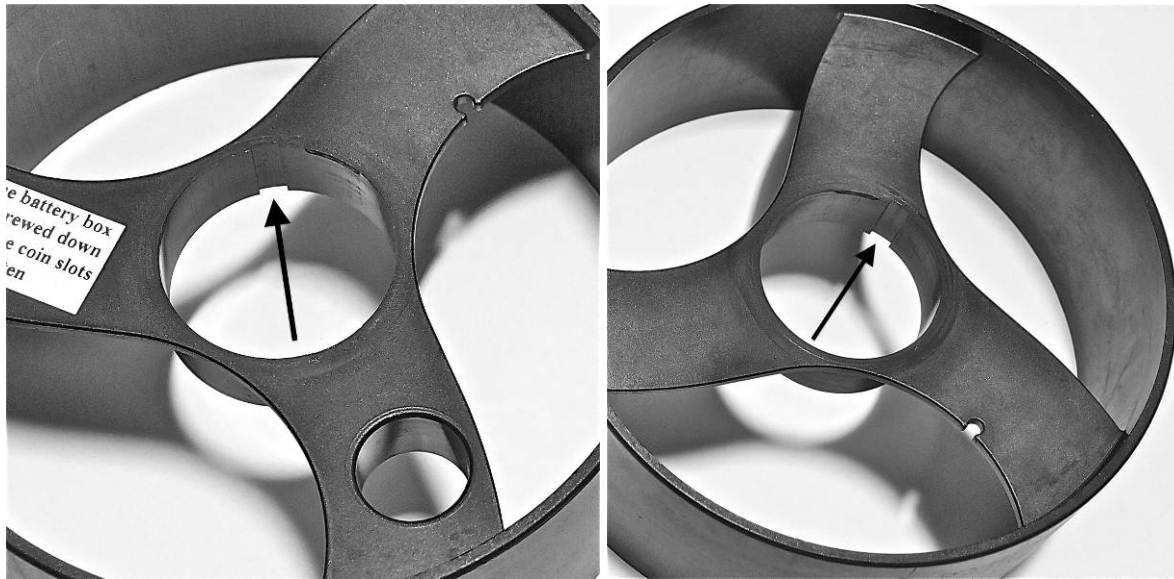

6.9 Place the scrubber lid back into the Inspiration rebreather

- Fit a new BS-010-N70 O-ring onto the MP oxygen hose that comes from either the gas distribution bar or the 1st stage (depending on the rebreather model).
- Re-attach the MP oxygen hose to the oxygen hose attachment (hand-tight; no tools!).
- Re-attach the corrugated inhale hose to the T-piece on the inhale counterlung.

7. Testing Instructions

7.1 Test for leaks without switching on the rebreather electronics

1. Attach an Oxygen cylinder to the 1st stage on oxygen side of the rebreather.
2. Slowly (= take a few seconds!) and gently open the O₂ cylinder valve.
3. Attach a medium pressure gauge (e.g. 0-15 bar) to the oxygen inflator hose that normally hooks into the oxygen inflator on the exhale counterlung to verify the correct intermediate pressure.
 - a. An Inspiration rebreather is normally delivered from the factory with such a small MP pressure gauge, suitable for this purpose.
 - b. The MP on the oxygen side should be 7,5 bar, and never higher than 8 bar.
-  **WARNING:** A higher MP might render the solenoid inoperative.
4. If the intermediate pressure is ok, remove the MP pressure gauge and re-attach the inflator hose to the O₂ inflator on the exhale counterlung.
5. Let the pressure rise and finally stabilize on the HP oxygen gauge (manometer).
6. Close the oxygen cylinder valve again.
7. Monitor the HP gauge, and listen for any hissing sound in the area of the solenoid and its attachment to the scrubber lid. The pressure on the HP gauge should stay stable and not drop, and no hissing sounds should be heard.
8. If leakage sounds are heard and/or the pressure on the HP gauge drops, depressurise the system by pressing the oxygen inflator on the exhale counterlung and search for the source of the problem.
9. If needed, repeat the process from step 2 above on until no more leaks are detected.

7.2 Test for proper operation and leaks with switched on rebreather electronics

1. If the system passes the passive leak test described above, open the oxygen valve again slowly and gently, start up the rebreather and monitor the normal solenoid activities during start-up and calibration. Monitor the usual clicking sounds and gas injection noises.
2. Once the system is calibrated, close the mouthpiece and close the oxygen cylinder valve again.
3. Now monitor the PO₂ on the handset(s) as well as and the pressure on the HP oxygen gauge:
 - a. The PO₂ on the handset(s) should not creep up, as that might indicate a leaking solenoid.
 - b. The pressure on the oxygen HP gauge should not drop, as that also indicates an oxygen leak.
4. Switch the handset to the high setpoint (1.3 bar), which causes the solenoid to inject oxygen repeatedly in intervals in a vain attempt to reach 1,3 bar (which it will of course never reach on the surface). Let this occur for a few minutes, while you monitor the oxygen opening and closing sounds and the gas injection sounds.
5. Now switch the handset(s) back to the low setpoint (0.7 bar), and once more watch for any increase in setpoint and/or drop in pressure on the oxygen HP gauge.
6. If all tests pass ok, your maintenance is performed successfully.