



RBV05 and RBV05A Rebreather Manual Inflator Maintenance Manual

Version 1.3
March 2017
Written by Tino de Rijk

Table of Contents

1. Introduction.....	3
1.1 Functional description.....	3
1.2 Servicing.....	3
1.3 Warranty.....	3
1.4 Copyright and Applicable Law.....	3
2. RBV05 Manual Inflator Exploded Diagram and Parts List.....	4
2.1 RBV05 (Diluent) and RBV05A (Oxygen) Manual inflators main assembly.....	4
2.2 RBV05/04 Counterlung Connection Post.....	5
3. RBV05B Service Kit Contents and Tools.....	6
3.1 RBV05B (Diluent) and RBV05B/1 (Oxygen) Service Kit Contents.....	6
3.2 Tools Needed.....	7
4. Disassembly Instructions.....	8
4.1 Remove MP hose and connection post from the counterlung.....	8
4.2 Remove DIN 9/16" UNF adapter from DIN cylinder post moulding.....	9
4.3 Remove MP hose from inflator body.....	10
4.4 Remove O-rings from MP hose.....	10
4.5 Remove inflator hose connector from inflator body.....	11
4.6 Remove 3/8" UNF plug from inflator body.....	12
4.7 Remove inflator spindle, spring and push button from inflator body.....	12
4.8 Remove O-rings from inflator connector, 3/8" UNF plug and inflator spindle.....	13
4.9 Remove outer O-ring from inflator body.....	14
4.10 Remove inner O-ring from inflator body.....	15
5. Clean and Replace Service Parts.....	16
5.1 Service kit contents.....	16
5.2 Ultrasonically clean deposits from all metal parts.....	17
5.3 Replace all O-rings and push button with new ones from the Service Kit.....	17
5.4 How to lightly grease O-rings.....	17
6. Assembly Instructions.....	20
6.1 Put new inner O-ring into inflator body.....	20
6.2 Put new outer O-ring into inflator body.....	22
6.3 Put new O-rings on inflator hose connector, 3/8" UNF plug and inflator spindle.....	23
6.4 Put inflator spindle, spring and push button into inflator body.....	24
6.5 Screw inflator hose connector into inflator body.....	26
6.6 Screw 3/8" UNF plug into inflator body.....	27
6.7 Put new O-rings onto MP hose.....	27
6.8 Screw MP hose into inflator body.....	28
6.9 Screw DIN 9/16" UNF adapter into DIN cylinder post moulding.....	29
6.10 Screw MP hose and connection post back into the counterlung.....	30
7. Testing Instructions.....	31
7.1 Test for leaks and proper operation.....	31

1. Introduction

1.1 Functional description

The AP Diving RBV05 and RBV05A manual inflators are balanced free-hanging inflators for the AP Diving Inspiration range of rebreathers that are fitted with back-mounted counterlungs.

1.2 Servicing

Before servicing the AP Diving RBV05 manual inflator, you must receive instruction and certification in the maintenance of this gas isolator by AP Diving Ltd.

Without the correct training it is possible to configure the manual inflator incorrectly in an unsafe manner. Factory or Dealer prescribed service for this gas isolator is recommended at least once annually.

The Inspiration range of closed circuit rebreathers' CE certification to EN14143 is unaffected by the fitting of this AP Diving RBV05 manual inflator.

This AP Diving RBV05 manual inflator meets the requirements of the Personal Protective Equipment Directive 89/686/EEC – CE certification when fitted to an AP Diving rebreather.

 **WARNING:** when servicing the AP Diving RBV05 manual inflator it is VERY important that all parts that may suffer wear and tear get replaced. It is also very important that the correct tools are used to avoid damaging any part of the inflator in the disassembly and assembly process. Please don't try to save money by re-using parts that really should be replaced during a proper servicing action.

 The numbers between brackets after the part names in the disassembly and assembly chapters correspond to the sequence numbers in the diagrams in chapter 2.

1.3 Warranty

This AP Diving RBV05 manual inflator is covered by AP Diving's 1-year warranty against defects in materials or workmanship. This warranty is only extended to the original purchaser, and is not transferable. For more information, be sure to read the warranty section of the user manual, and the purchaser should save the sales receipt.

A copy of the receipt must be presented whenever obtaining warranty service.

1.4 Copyright and Applicable Law

This Maintenance Manual is copyrighted, all rights reserved. It may not, in whole or in part, be copied, photocopied, reproduced, translated, or reduced to any electronic medium (including the Internet) or machine-readable form without prior consent in writing from AP Diving Ltd.

All products are sold on the strict understanding that only English Law applies in cases of warranty claims and product liability, regardless of where the equipment is purchased or used. Should a claim be made then the venue for this would be in Truro, England.

© 2017 AP Diving Ltd.

AP Diving RBV05 Manual Inflator Maintenance Manual

2. RBV05 Manual Inflator Exploded Diagram and Parts List

2.1 RBV05 (Diluent) and RBV05A (Oxygen) Manual inflators main assembly

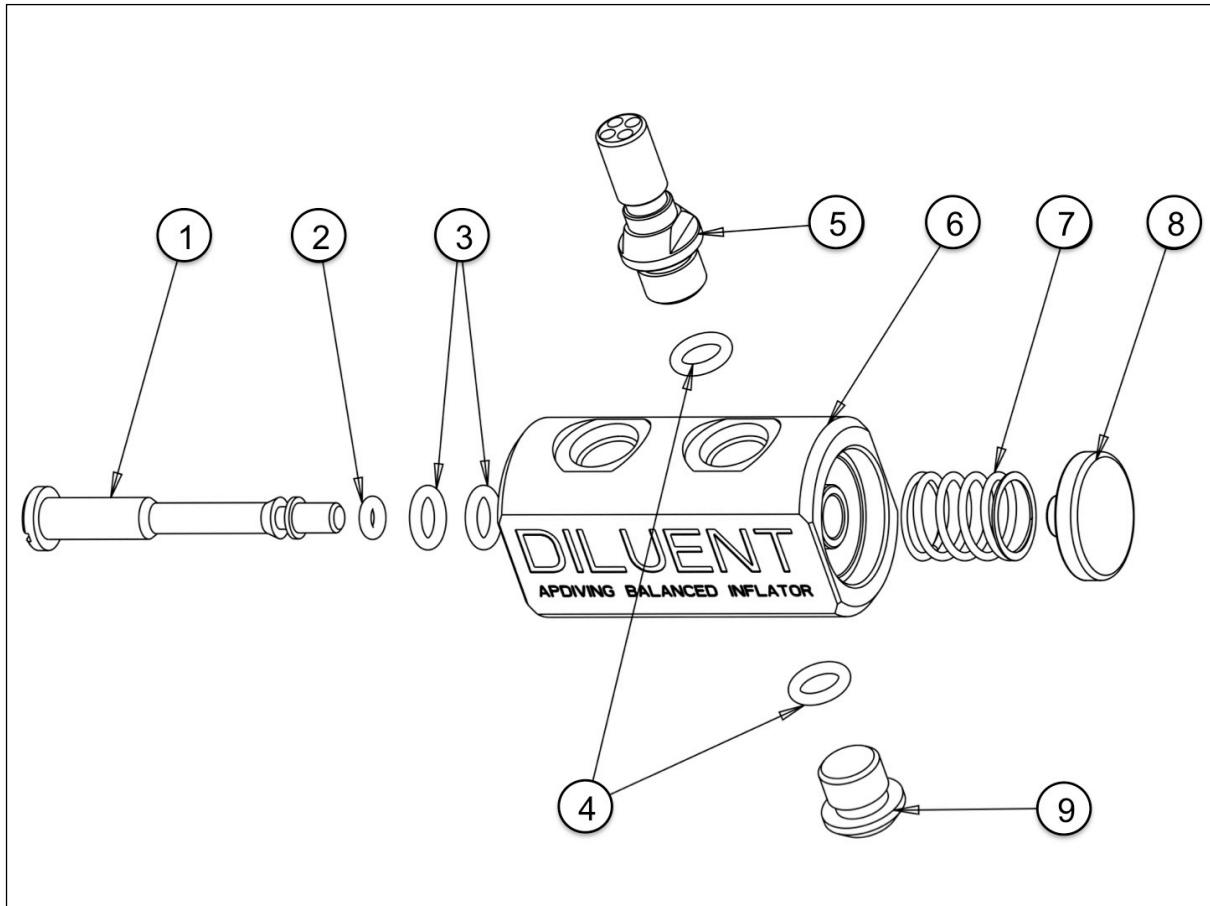

<u>NUMBER</u>	<u>TYPE</u>	<u>DESCRIPTION</u>	<u>PART NUMBER</u>	<u>QUANTITY</u>
1	RBV05	Inflator spindle	RBV_05_02	1
2	RBV05	BS006 O-ring	BS_006_N70	1
3	RBV05	BS010 O-ring	BS_010_N70	2
4	RBV05	BS903 O-ring	BS_903_N70	2
5	RBV05	Manual inflator connector	RBV_05_03	1
6	RBV05	Inflator body – DILUENT	RBV_05_01	1
6	RBV05A	Inflator body – OXYGEN	RBV_05_01A	1
7	RBV05	AP52 spring	AP_43_A	1
8	RBV05	AP52 button – DILUENT	AP_43_B	1
8	RBV05A	AP52 button - OXYGEN	AP_43_G	1
9	RBV05	3/8" UNF plug	RB_14_01	1

2.2 RBV05/04 Counterlung Connection Post

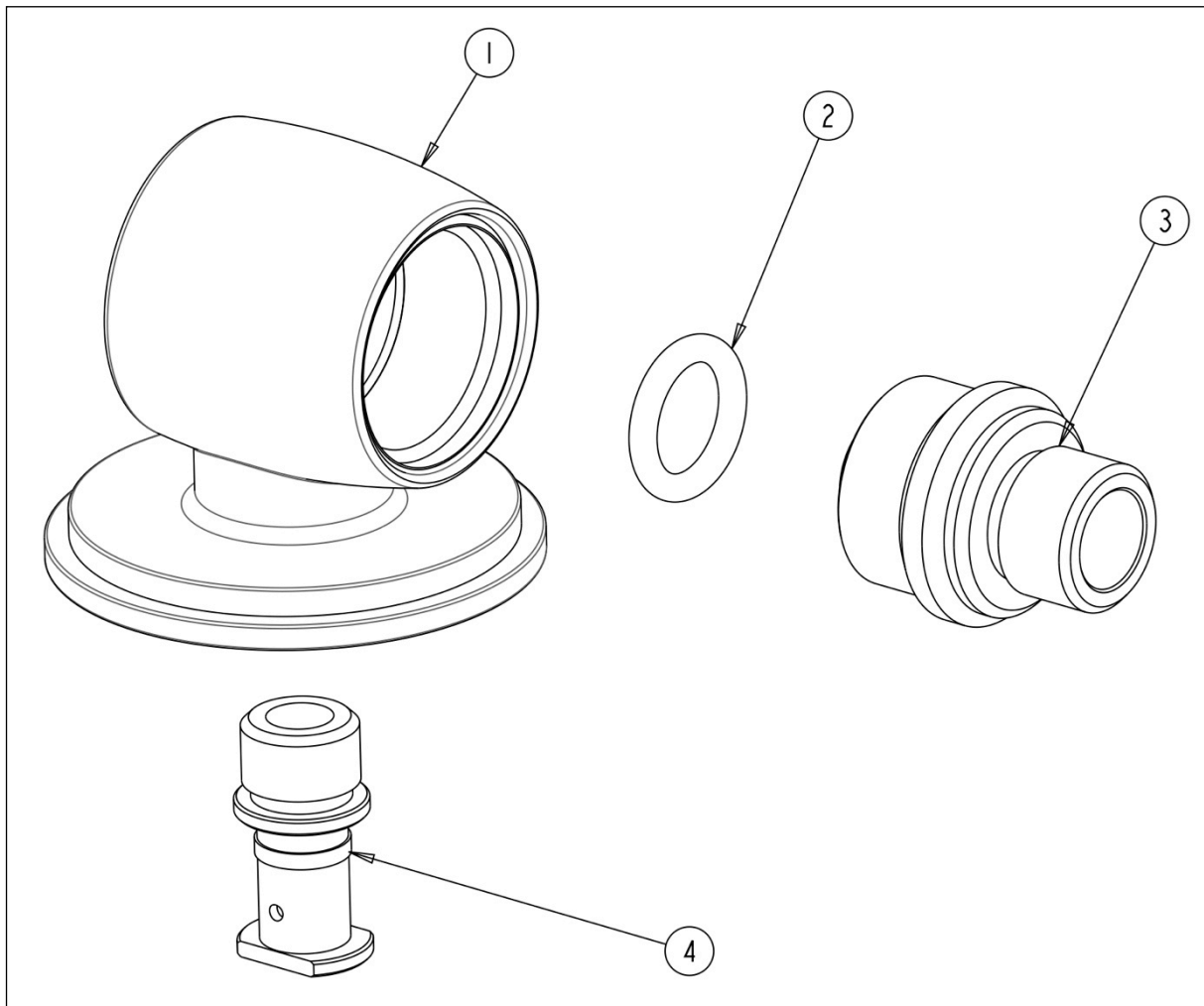

NUMBER	DESCRIPTION	PART NUMBER	QUANTITY
1	DIN cylinder post moulding	AP_35_1	1
2	BS111 O-ring	BS_111_N90	1
3	DIN 9/16" UNF adapter	AP_35_R	1
4	Valve stem	AP_35_J	1

3. RBV05B Service Kit Contents and Tools

3.1 RBV05B (Diluent) and RBV05B/1 (Oxygen) Service Kit Contents

⚠ WARNING: When replacing O-rings, next to the size, the hardness of the O-rings (declared in degrees Shore, and is indicated by the suffixes N70 and N90) is ESSENTIAL for proper operation. AP Diving deliberately chooses the N70 hardness of the O-rings for the RBV05 inflator.

If, against our recommendation, you choose to select your O-rings to come from another source than 7P Diving Ltd., make sure you select the right type in size AND hardness AND material (composition).

When servicing the RBV05 inflator the following parts need to be replaced, as present in the RBV05B (diluent inflator) and RBV05B/1 (oxygen inflator) service kits:



<u>NUMBER</u>	<u>WHERE DOES IT GO?</u>	<u>DESCRIPTION</u>	<u>PART NUMBER</u>	<u>QUANTITY</u>
1	Inflator	BS006 O-ring	BS_006_N70	1
2	Inflator and MP hose	BS010 O-ring	BS_010_N70	3
3	Inflator and MP hose	BS903 O-ring	BS_903_N70	3
4	Inflator	AP52 BLUE Diluent Button or AP52 GREEN Oxygen Button	AP_43_B AP_43_G	1
5	Connection post	BS111 O-ring	BS_111_N90	1
6	Post Base	BS222 O-ring	BS_222_N50	1

3.2 Tools Needed

There are no special tools needed for servicing the RBV05 inflator.

Normal tools needed are:

- 5 mm Allen key
- 17 mm spanner
- 2 x 6 mm drills
- O-ring picking tools
- Oxygen-compatible grease
 - o see chapter 5 for remarks about when you need to keep this device in oxygen service
- (Access to) an ultrasonic bath for cleaning the metal parts.



WARNING: Do NOT use aggressive chemicals. They might damage the metal plating of the RBV05 inflator. Use an ultrasonic cleaning bath with a suitable cleaning fluid. A very good cleaning fluid is Biox "O2" immersion fluid. See WWW.BIOXINT.COM for further information and distributors.

The use of rubber gloves while re-assembling the RBV05 inflator is recommended to avoid rendering the RBV05 inflator oxygen unclean due to human touch.

4. Disassembly Instructions

4.1 Remove MP hose and connection post from the counterlung

- Unscrew the counterlung connection-post retaining ring and remove the post from the back-mounted counterlung.
- Replace the large BS222 O-ring in the connection base with the new one supplied in the service kit.

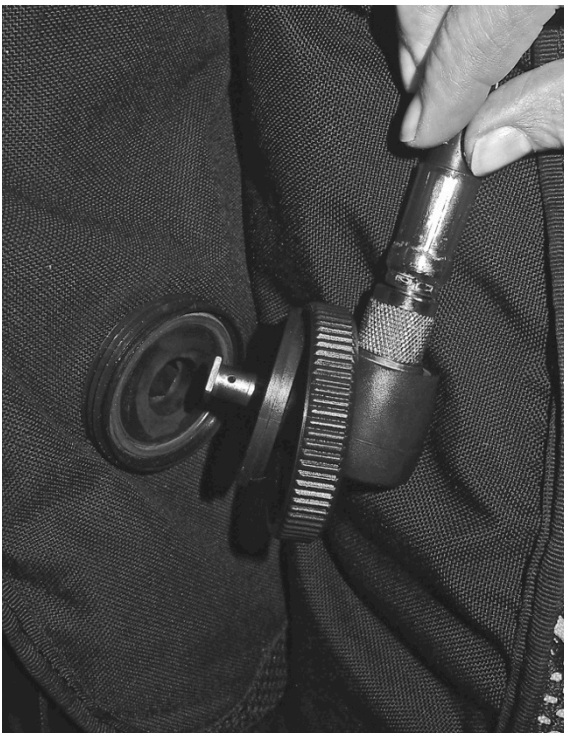

4.2 Remove DIN 9/16" UNF adapter from DIN cylinder post moulding

- Use a 5 mm Allen key to remove the DIN adapter from the cylinder post.
- Use an O-ring picking tool to remove the O-ring from the adapter.



4.3 Remove MP hose from inflator body

- Use a 17 mm spanner to remove the MP hose from the inflator body

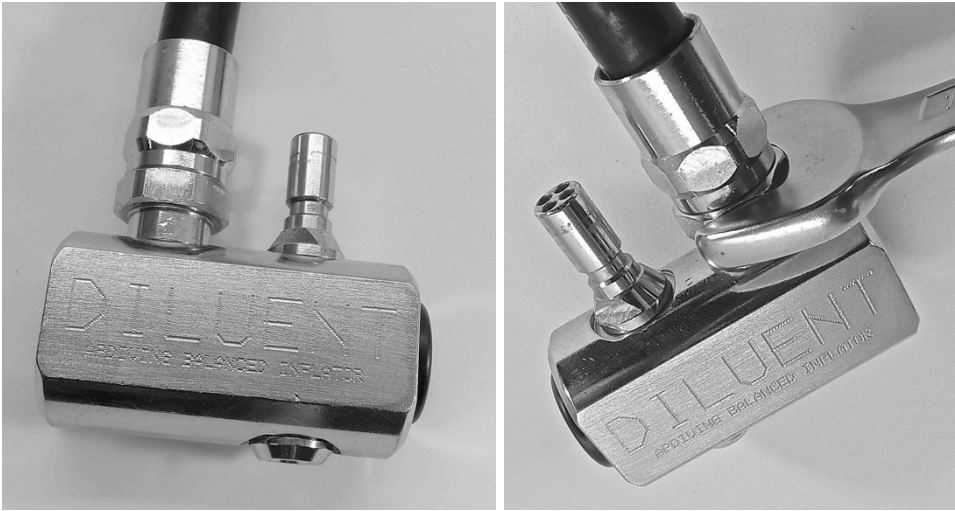

4.4 Remove O-rings from MP hose

- Remove O-rings from both ends of the MP hose.

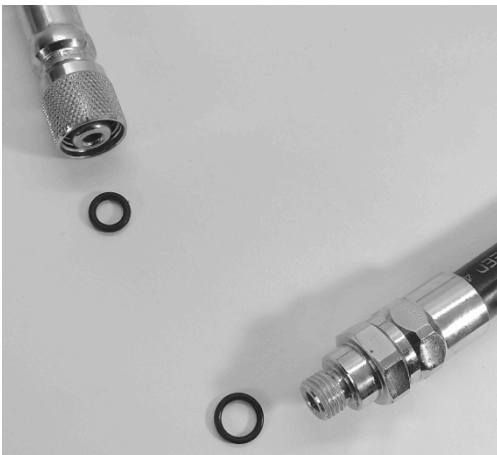

4.5 Remove inflator hose connector from inflator body

- Use an 8 mm spanner to unscrew the inflator hose connector from the inflator body.

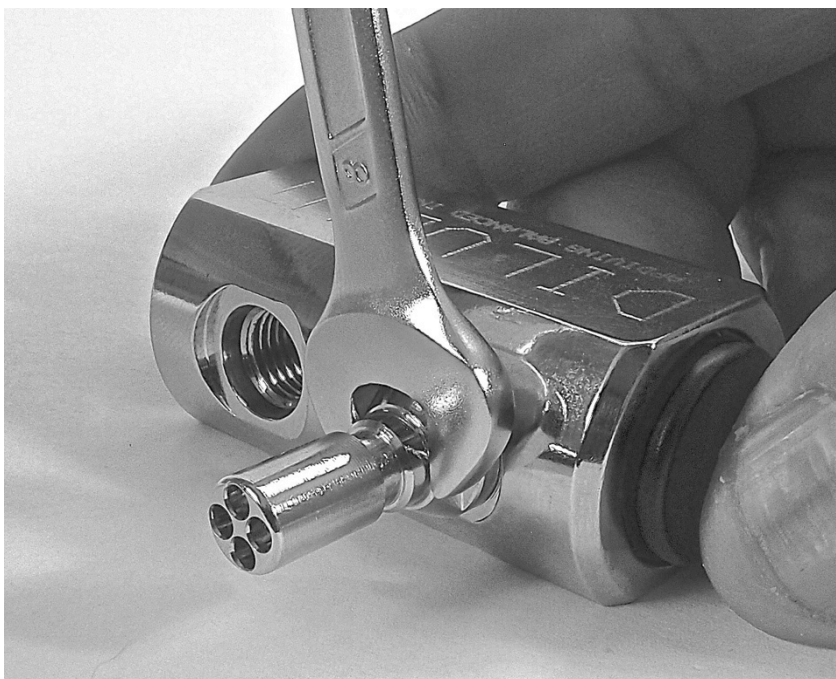

4.6 Remove 3/8" UNF plug from inflator body

- Use a 5 mm Allen key to unscrew the UNF plug from the inflator body.



4.7 Remove inflator spindle, spring and push button from inflator body

- While holding the green (oxygen) or blue (diluent) push-button in place, use a screwdriver to unscrew the inflator spindle from the push button.
- Make sure you do not lose the spring!

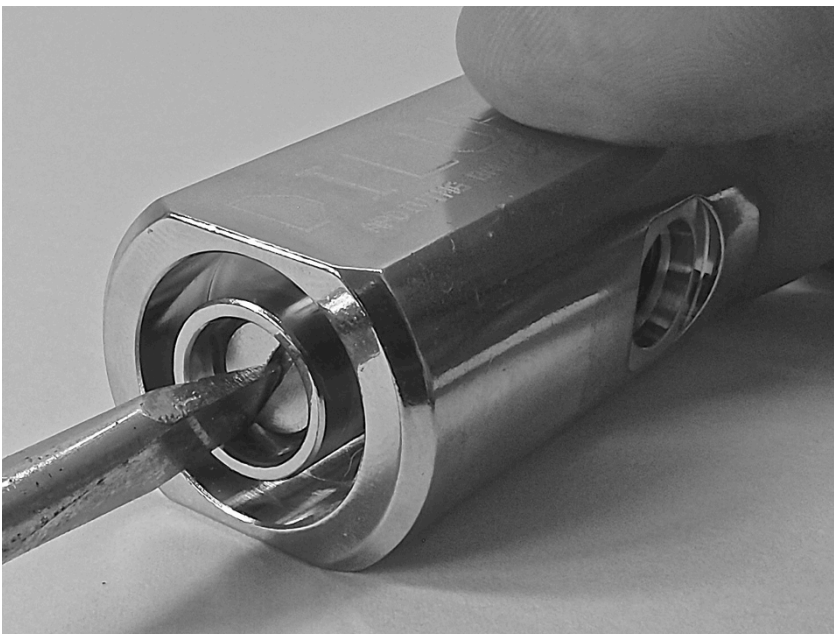



4.8 Remove O-rings from inflator connector, 3/8" UNF plug and inflator spindle

- Remove O-rings from the parts just removed from the inflator body: inflator hose connector, UNF plug and spindle.



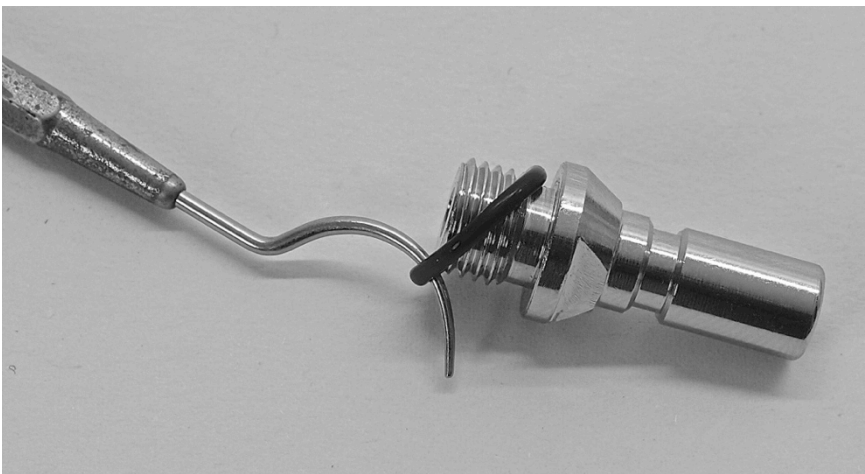
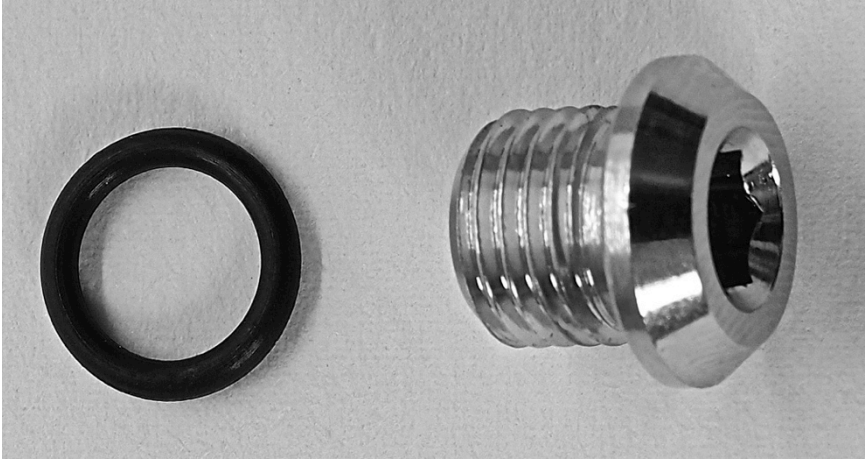

4.9 Remove outer O-ring from inflator body

- Use a blunt O-ring picking tool to remove the outer O-ring from the inflator body.
- Take care not to damage the O-ring groove!



4.10 Remove inner O-ring from inflator body

-  **WARNING:** This O-ring resides in the very centre of the inflator body and is quite hard to reach. You will most likely damage the O-ring in the removal process.
- Make sure you do not damage the O-ring groove while removing the O-ring!

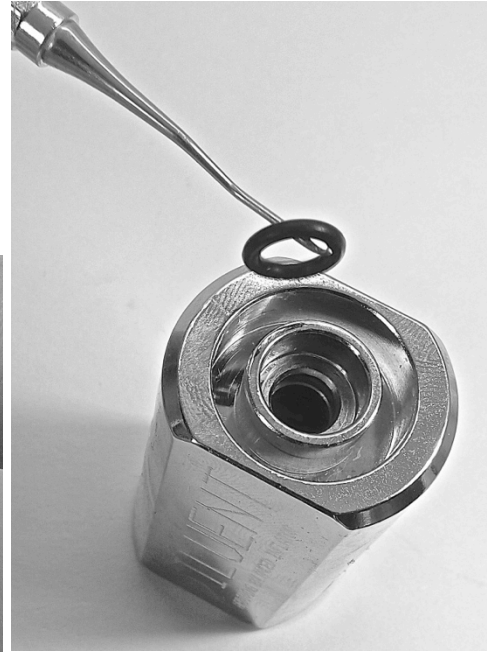
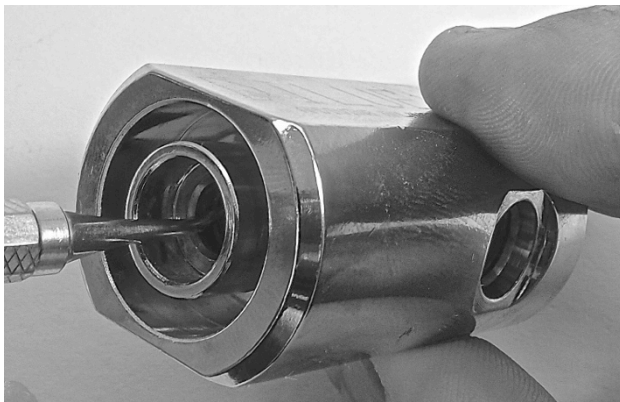

5. Clean and Replace Service Parts

The servicing of the RBV05(A) inflator contains 4 “action groups”:

1. Removing and binning all parts that should be replaced. This includes all O-rings.
2. Depending on the gas content the RBV05(A) inflator is exposed to, keep it in oxygen service. The CGA (Compressed Gas Association), US Navy, UK’s HSE and the EIGA (European Industrial Gas Association) all recommend that breathing gasses with an oxygen content of 23.5% or higher should be treated as 100% oxygen. However, some technical training agencies still use 40% as the maximum percentage that is allowed for equipment that is not in oxygen service.
AP Diving advises to err on the side of safety, and to use the value of 23.5% as the cutoff percentage beyond which the equipment must be in oxygen service.
If in doubt: keep it in oxygen service, as that only takes a little bit more effort.
 - Obviously, the RBV05A **MUST** be kept in oxygen service at all times, as it will be exposed to 100% oxygen during normal use.
3. Ultrasonic-cleaning of all disassembled metal parts. This is mandatory if the RBV05(A) inflator is to be kept in oxygen service, but recommended in all other servicing situations.
4. Lightly grease new parts, fit them, and re-assemble the RBV05(A) inflator with the correct tools and the correct torques. Use oxygen-compatible grease, and avoid contaminating the metal parts after cleaning. Use the smallest amount of grease possible.

The use of rubber gloves while re-assembling the RBV05 Inflator is mandatory if the RBV05 is to be kept in oxygen service. This is to avoid rendering the RBV05 Inflator unclean due to human touch (skin oils, sweat).

5.1 Service kit contents

As described in chapter 3.1, the following parts need to be replaced when servicing the RBV05 Inflator:

<u>NUMBER</u>	<u>WHERE DOES IT GO?</u>	<u>DESCRIPTION</u>	<u>PART NUMBER</u>	<u>QUANTITY</u>
1	Inflator	BS006 O-ring	BS_006_N70	1
2	Inflator and MP hose	BS010 O-ring	BS_010_N70	3
3	Inflator and MP hose	BS903 O-ring	BS_903_N70	3
4	Inflator	AP52 BLUE Diluent Button or AP52 GREEN Oxygen Button	AP_43_B AP_43_G	1
5	Connection post	BS111 O-ring	BS_111_N90	1
6	Post Base	BS222 O-ring	BS_222_N50	1

5.2 Ultrasonically clean deposits from all metal parts

Clean deposits from all metal parts, like chalk and salt.

 **WARNING:** Do NOT use aggressive chemicals. They might damage the metal plating. Use an ultrasonic cleaning bath with a suitable cleaning fluid instead. A good cleaning fluid is Biox "O2" immersion fluid. See WWW.BIOXINT.COM for further information and distributors.

5.3 Replace all O-rings and push button with new ones from the Service Kit

 **WARNING:**

- You might be tempted to re-use the blue or green push-button (even though a new one is part of the service kit). However you should NEVER do this: the push-button holds onto the spindle through friction, preventing it un-screwing. If you reuse the push-button, you significantly increase the risk that the push-button "auto-unscrews" from the spindle during use, as the plastic thread-lock effect will not be as effective due to removing and replacing.

 **WARNING:**

- Replace all O-rings: do NOT re-use old ones.
- ONLY use original parts from AP Diving, to make sure the O-rings:
 - o Are the exact size
 - o Are of the correct material (especially important in a high oxygen content and overpressure environment)
 - o Are of the correct stiffness (degrees Shore).
- Make sure you use only oxygen-compatible grease.
- Also make sure you only use oxygen-clean and oxygen-compatible replacement parts.

All AP Diving-supplied O-rings in the service kit are made from Nitrile and as such are oxygen compatible. However, they still need to stay or be made oxygen-clean.
- Last but not least: avoid touching oxygen-clean parts after cleaning with your bare hands. Human body sweat and grease are not oxygen-compatible. So use rubber gloves (e.g. surgical) when re-assembling the RBV05 Inflator.
- For photographic clarity no rubber gloves are worn on the photos in this manual.

5.4 How to lightly grease O-rings

When greasing O-rings, make sure NOT to use too much grease.

Especially O2 compatible grease has the potential to become stiffer over time, which may cause a hardened clot of grease to become a source for leaking.

The best way to grease O-rings is using a simple "grease bag".

A grease bag is a clean and clear plastic bag, into which you put a small amount of grease.

Optionally you can make two bags: one with O2 compatible grease, and one with normal silicone grease. Make sure you label them properly to avoid mixing them up! Also put a date on it, so you know how old your grease bag is. Don't use them longer than a year.

A nice advantage of using a grease bag is that you use only a tiny amount of grease for greasing many O-rings, so there is little waste.

We recommend that you use resealable bags, e.g. the ones with a plastic zipper, typically used for airtight food storage. This allows you to zip up the bag after use, keeping the contents clean for repeated use.

The simple steps are as follows:

- Take a plastic bag and deposit a SMALL amount of grease in it.

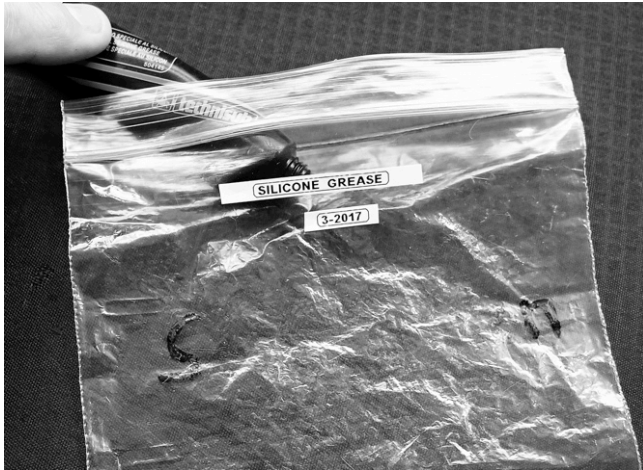

- Massage this grease all around the bag until it is evenly distributed over the inside surface area.
- Take the O-rings to be greased out of their storage container, either using gloves or using an O2-cleaned instrument like a dentist hook.



- Drop them in the grease bag, and from the outside of the bag move them around with your fingers, making sure they get in full contact with the grease.



- Open the bag, and using a clean instrument like a dentist hook, take the now properly greased O-rings out.
- Inspect them to make absolutely sure that the grease is evenly and lightly distributed on the O-rings and that there are no areas of excess grease - no globs or strands.
- Fit them where they belong on your diving equipment, still making sure not to touch them with your bare hands.

6. Assembly Instructions

⚠ WARNING: When assembling the RBV05 Inflator, use rubber gloves to avoid polluting it while assembling, rendering it not oxygen-clean anymore.

6.1 Put new inner O-ring into inflator body

- **⚠ WARNING:** This O-ring resides in the very centre of the inflator body and is quite hard to reach. Below you will find a “trick” to make life easier for you.
- For that you need three tools:
 - 2 x 6 mm drills;
 - A paperclip, bent as shown below. Un-sharpen the bent end.
- Make sure you oxygen-clean drill bits and paperclip before use!



- Use the bent paperclip to move the O-ring roughly into position, into the centre of the inflator body, as shown in the 4 pictures below.

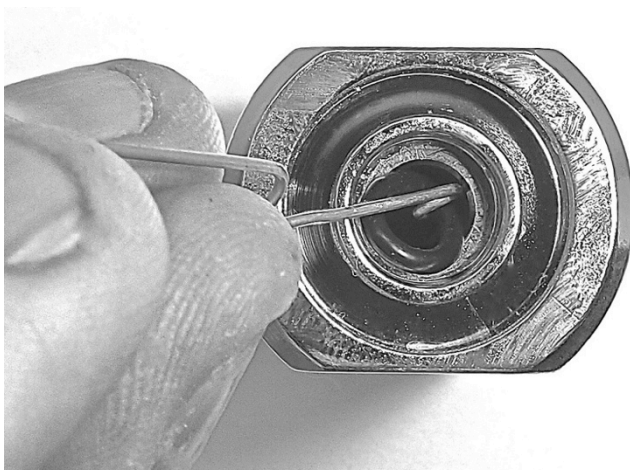

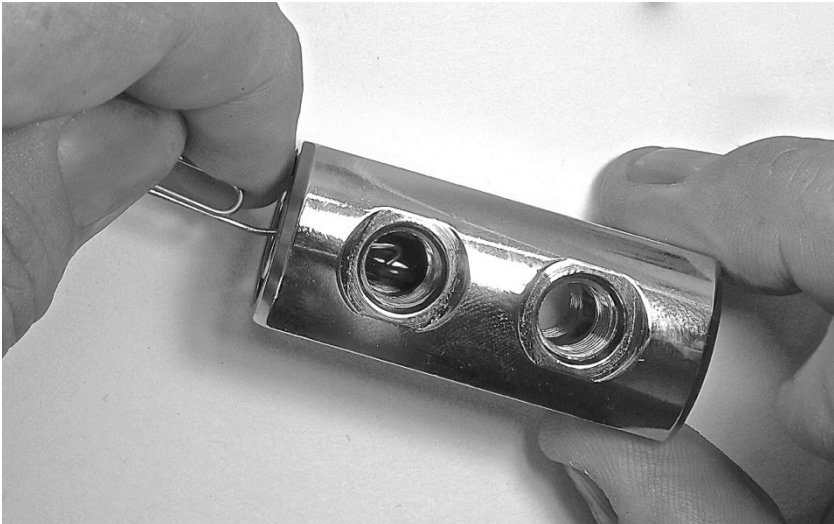

- Next, remove the paperclip and insert the blunt backends of the drills (i.e. NOT the sharp drilling ends!) from both sides into the inflator body.
- This way you “lock up” the O-ring between the two flat drill ends, forcing it to rotate and enter its groove.
- You may have to “wiggle” the drills a bit from left to right to force the O-ring into its groove.

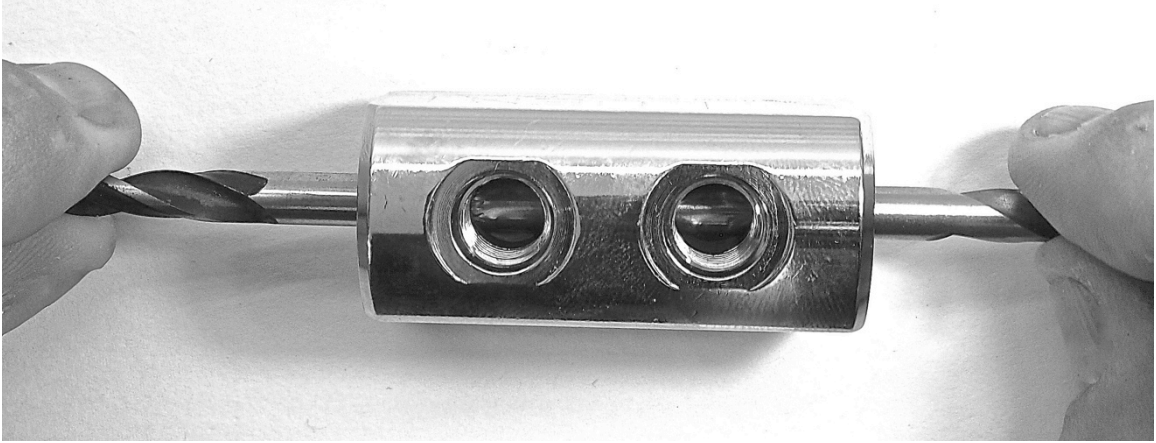

6.2 Put new outer O-ring into inflator body

- Use the bent paperclip again as well as normal O-ring picking tools to put a new O-ring into the outer O-ring groove.

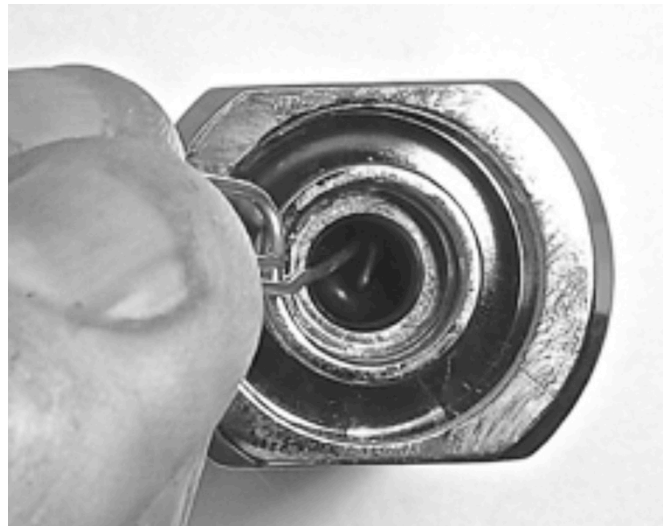
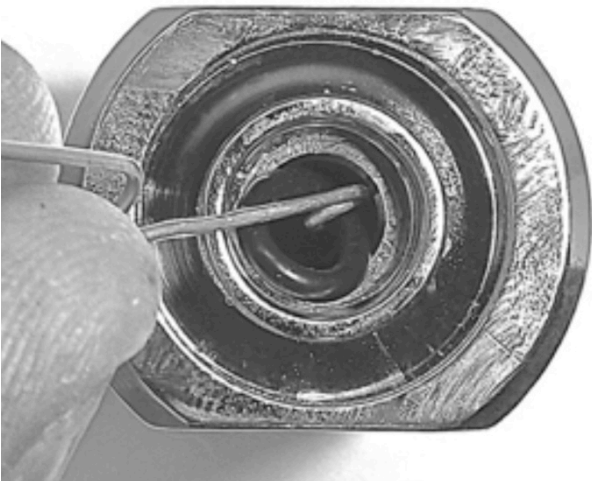

6.3 Put new O-rings on inflator hose connector, 3/8" UNF plug and inflator spindle

- Put new O-rings on the three parts that screw into the inflator body: inflator hose connector, 3/8" UNF plug and inflator spindle.

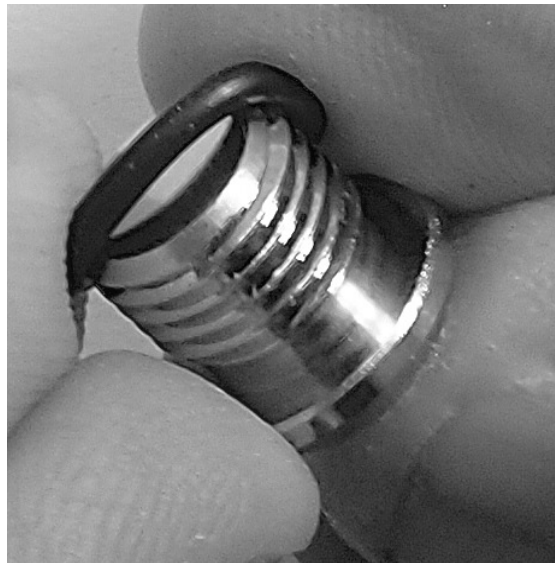
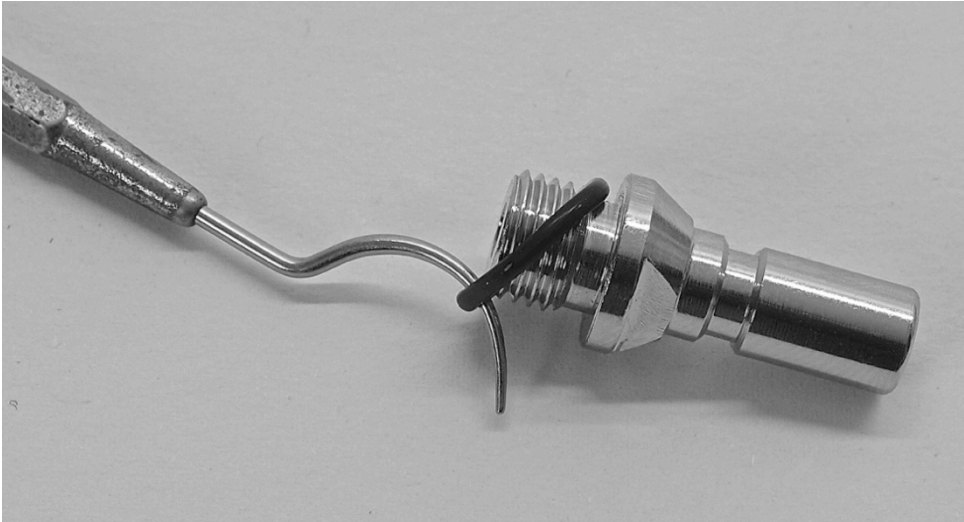

6.4 Put inflator spindle, spring and push button into inflator body

- Push the spindle into the inflator body. Insert it from the side with the small hole; the other side has a bigger hole that holds the spring and push button.



- Insert spring on other end (with the bigger hole).



- Screw a new push-button onto the exposed thread of the spindle and nip it up with a screwdriver, inserted into the spindle end.
- ALWAYS use a fresh push button to maintain the thread-lock effect.



6.5 Screw inflator hose connector into inflator body

- Use an 8 mm spanner to screw the inflator hose connector back into the inflator body.
- Notice the position of the inflator hose connector: it screws into the topline of the inflator body, on the side of the push button, opposite the UNF plug.



6.6 Screw 3/8" UNF plug into inflator body

- Use a 5 mm Allen key to screw the 3/8" UNF plug back into the inflator body.
- Notice the position of the UNF plug: it screws into the bottom of the inflator body, on the side of the push button side, opposite the inflator hose connector.



6.7 Put new O-rings onto MP hose

- Put new O-rings onto both ends of the MP hose.
- NOTE: they are NOT the same size!

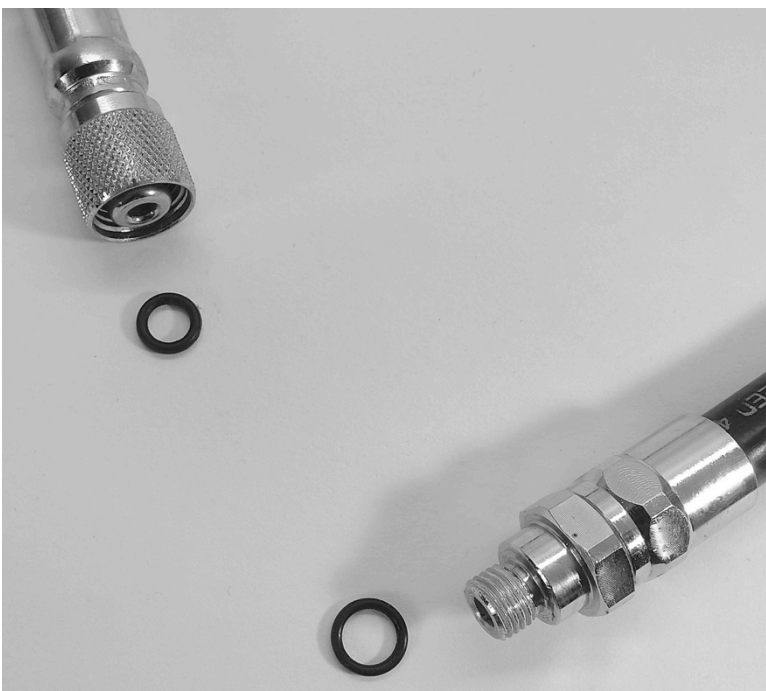

6.8 Screw MP hose into inflator body

- Use a 17 mm spanner to screw the MP hose back into the inflator body.
- Notice the position of the MP hose: it screws into the topside of the inflator body, opposite of the push button.

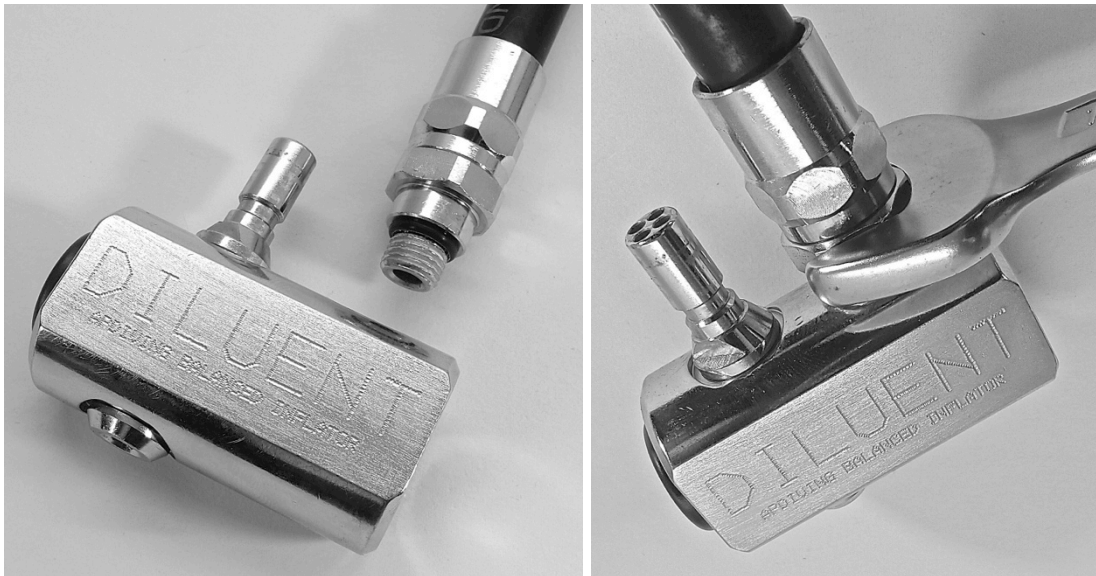

6.9 Screw DIN 9/16" UNF adapter into DIN cylinder post moulding

- Put new O-ring onto DIN 9/16" UNF adapter.
- Use a 5 mm Allen key to screw the UNF adapter back into the cylinder post moulding.



6.10 Screw MP hose and connection post back into the counterlung

- Inspect the big O-ring that remains in the connection base for damage. Replace if damaged.
- Screw the counterlung connection post back into the back-mounted counterlung.
- Firmly hand-tighten it into the correct position (typically pointing up).



7. Testing Instructions

7.1 Test for leaks and proper operation

- Pressurize the MP hose to which the RBV05 Inflator is in-line connected by slowly opening the associated HP cylinder valve (diluent or oxygen).
- Listen for any leaks (hissing sounds).
- Press the push button several times and check for proper and smooth operation (i.e. proper inflation of the counterlungs).
- Submerge the pressurized inflator in water and monitor for any bubbles coming out.
- Close the cylinder valve and monitor the HP gauge. The pressure should not drop.
- Perform the usual positive and negative leak breathing loop tests, verifying that there are no leaks in e.g. the connection post.