



## **FS101/FS101A 1<sup>st</sup> Stage Maintenance Manual**

Version 1.3  
March 2017  
Written by Tino de Rijk  
Page 1 of 39

## Table of Contents

1. Introduction .....	4
Copyright and Applicable Law .....	4
2. FS101/FS101A 1 <sup>st</sup> stage diagram and parts list .....	5
3. Service kit contents and special tools .....	7
3.1 Service kit contents .....	7
3.2 Special tools .....	8
4. Disassembly instructions .....	10
4.1 Remove all four 3/8" UNF medium port plugs .....	10
4.2 Remove the two 7/16" UNF high pressure port plugs .....	10
4.3 Screw special tool FS TOOL 2 in a 7/16" UNF high pressure port .....	11
4.4 Remove DIN wheel assembly .....	12
4.5 Unscrew the HPV housing assembly .....	13
4.6 Remove balance spring and HPV .....	13
4.7 Remove small BS006N90 from inside of HPV housing .....	14
4.8 Remove turret, body washer and big O-ring .....	14
4.9 Use FS TOOL 3 to unscrew the end cap .....	15
4.10 Remove medium pressure spring and balancing spring seat .....	16
4.11 Remove the MP threaded insert .....	16
4.12 Remove the diaphragm .....	17
4.13 Remove the load transmitter pin .....	17
4.14 Unscrew the HPV insert cap .....	18
4.15 Push the HPV seat insert out of the main body .....	18
5. Clean and replace service parts .....	20
5.1 Service kit contents .....	20
5.2 Remove BS006 N90 O-ring from the inside of HPV housing .....	21
5.3 Ultrasonically clean deposits from all metal parts .....	21
5.4 Replace all O-rings with new ones from the service kit .....	21
5.5 Replace BS006 N90 O-ring into the inside of HPV housing .....	22
6. Assembly instructions .....	25
6.1 Push the new HPV insert with its O-ring into the main body .....	25
6.2 Screw the HPV insert cap into the main body .....	26
6.3 Place the load transmitter pin into the main body .....	26
6.4 Put the diaphragm into the main body .....	27
6.5 Screw the MP threaded insert into the open end cap .....	27
6.6 Place the medium pressure spring and the balancing spring seat on top of the diaphragm .....	28
6.7 Use FS tool 4 to screw the open end cap into the main body .....	28
6.8 Place body washer, big O-ring and turret on the main body .....	30
6.9 Place balance spring and push HPV into HPV housing .....	31
6.10 Place swivel washer and screw the HPV housing assembly through the turret into the main body .....	31
6.11 Screw DIN wheel, DIN stem, collar spacer, bronze filter and sealing O-ring into the main body .....	32

6.12 Unscrew special tool FS TOOL 2 from its 7/16" UNF high pressure port.....	33
6.14 Screw the 3/8" UNF medium port plugs into the turret .....	34
6.15 Screw an overpressure release valve into a 3/8" UNF medium port .....	34
7. Testing instructions.....	36
7.1 Screw a medium pressure hose, fitted with a medium pressure gauge, into a 3/8" UNF medium port .....	36
7.2 Optionally screw a second stage into a 3/8" UNF medium port.....	36
7.3 Screw MP threaded insert into the end cap, leaving approximately 2mm of the insert showing .....	37
7.4 Attach assembled 1 <sup>st</sup> stage onto a 50 bar air (FS101) or oxygen-compatible clean air (FS101A) source and slowly open valve.....	37
7.5 Watch medium pressure build up .....	38
7.6 Close gas source, release pressure and adjust medium pressure if needed ....	38
7.7 Repeat steps 7.4 through 7.6 with a high pressure (200 bar) gas source .....	39

## 1. Introduction

The AP Diving FS101 and FS101A 1<sup>st</sup> stages are state-of-the-art 1<sup>st</sup> stages, utilising a diaphragm-based balanced design, a special port layout scheme and a special design to battle freezing.

Of course this 1<sup>st</sup> stage is CE approved and designed to easily pass the EN250:2000 norm for performance and anti-freezing.

These stages are designed specifically for the AP Inspiration range of closed-circuit rebreathers. This has resulted in the following special features:

- 4 LP ports and 2 HP pressure ports that are placed in a non-standard position to accommodate perfect hose routing within the casing of the Inspiration rebreathers, both on the diluent- (FS101) and oxygen-side (FS101A) of the rebreather.
- An anti-freeze approach utilising large stream-through ports on the diaphragm side of the 1<sup>st</sup> stage, allowing the ambient water to transfer its above-zero warmth to the 1<sup>st</sup> stage. The material choices made all support this heat transfer.
- A very stable medium pressure delivery, even at depth. This is accomplished by using the above described heat transfer approach instead of the more popular “sealing” approach. Sealed 1<sup>st</sup> stages (where the diaphragm is kept isolated from the environment by an oil- or air-filled space and a second, flexible membrane) typically creep up in medium pressure at depth, as such bringing with them the danger of a solenoid not operating due to the medium pressure being too high.

The design and gas delivery capacity of this 1<sup>st</sup> stage is such that it will easily accommodate open-circuit usage at depth as well. When used in a rebreather, this means this 1<sup>st</sup> stage can also fulfil an “open circuit bail-out” role when needed at any depth the Inspiration rebreathers are rated for.

 **WARNING:** when servicing a 1<sup>st</sup> stage, it is VERY important that all parts that may suffer wear and tear get replaced. It is also very important that the correct special tools are used to avoid damaging any part of the 1<sup>st</sup> stage in the disassembly and assembly process. Please don't try to save money by re-using parts that really should be replaced during a proper servicing action.

 The numbers between brackets after the part names in the disassembly and assembly chapters correspond to the sequence numbers in the diagram on the next page and the first column in the parts list on page 5.

### Copyright and Applicable Law

This Maintenance Manual is copyrighted, all rights reserved. It may not, in whole or in part, be copied, photocopied, reproduced, translated, or reduced to any electronic medium (including the Internet) or machine-readable form without prior consent in writing from AP Diving Ltd.

All products are sold on the strict understanding that only English Law applies in cases of warranty claims and product liability, regardless of where the equipment is purchased or used. Should a claim be made then the venue for this would be in Truro, England.

## 2. FS101/FS101A 1<sup>st</sup> stage diagram and parts list

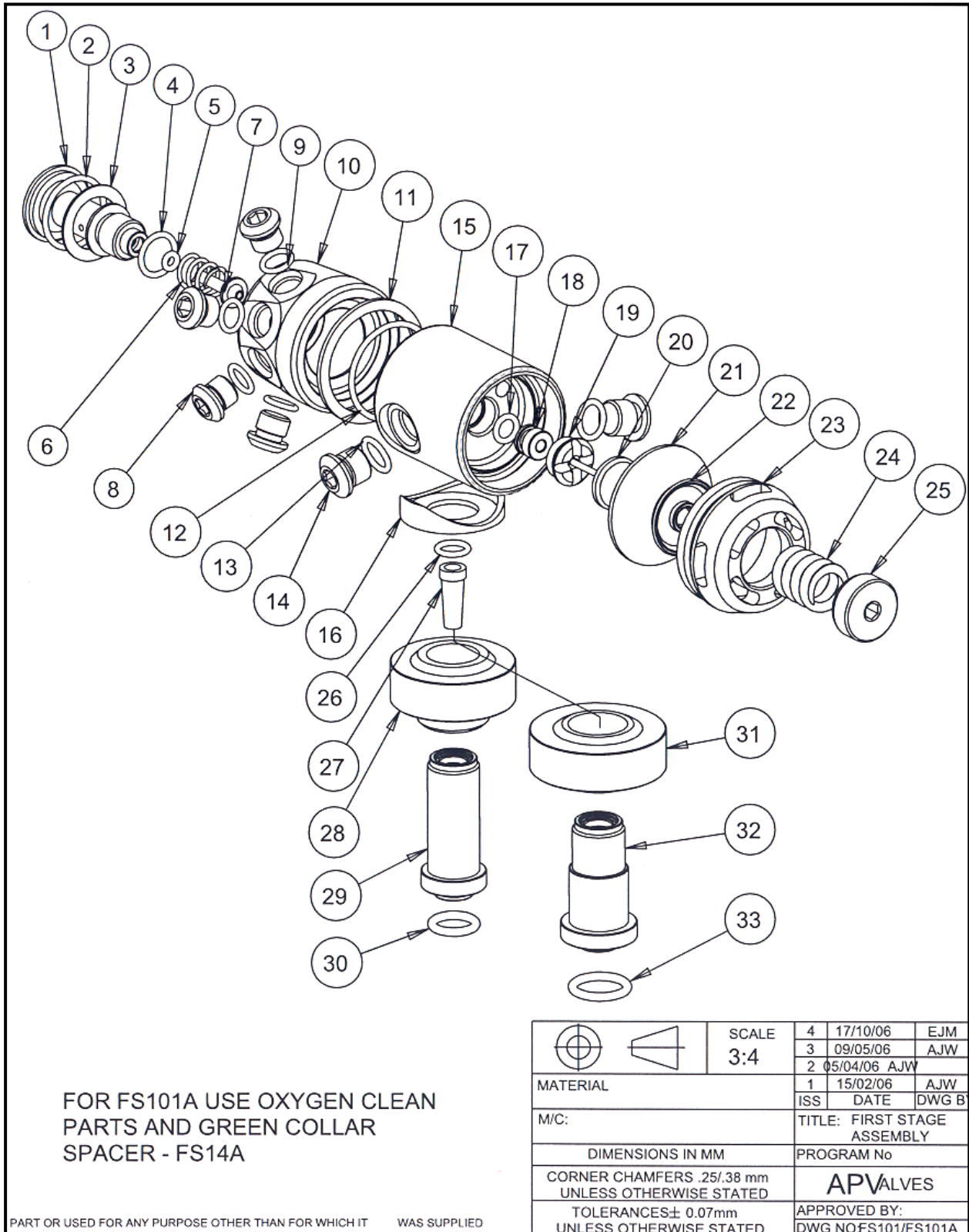

<u>NO</u>	<u>PART NAME</u>	<u>MATERIAL</u>	<u>PART NO</u>	<u>ISSUE</u>	<u>QUANTITY</u>
1	HPV HOUSING	BRASS	FS04	2	1
2	BS019 N70 O-RING	NITRILE	BS019N70	N/A	1
3	SWIVEL WASHER	POLYPROP	FS05	2	1
4	BS806 N70 O-RING	NITRILE	BS806N70	N/A	1
5	BS006 N90 O-RING	NITRILE	BS006N90	N/A	1
6	BALANCE SPRING	S. STEEL	FS06	1	1
7	HIGH PRESSURE VALVE (HPV)	S.STEEL	FS07/1	1	1
8	3/8" UNF PLUG	BRASS	FS14/01	1	4
9	BS903 N70 O-RING	NITRILE	BS903N70	N/A	4
10	TURRET	BRASS	FS02	2	1
11	BODY WASHER	POLYPROP	FS08	1	1
12	BS024 N70 O-RING	NITRILE	BS024N70	N/A	1
13	BS012 N90 O-RING	NITRILE	BS012N90	N/A	2
14	7/16" UNF PLUG	BRASS	FS18	1	1
15	BODY	BRASS	FS01/1	2	1
16	COLLAR SPACER	POLYPROP	FS14 (A)	1	1
17	BS010 N90 O-RING	NITRILE	BS010N90	N/A	1
18	HIGH PRESSURE VALVESEAT INSERT	PCTFE	FS20	1	1
19	HIGH PRESSURE VALVESEAT INSERT CAP	BRASS	FS21	1	1
20	LOAD TRANSMITTER PIN	BRASS	FS09/1	1	1
21	DIAPHRAGM	NBR	FS10/1	2	1
22	BALANCING SPRING SEAT	ACETAL	FS11/1	1	1
23	OPEN END CAP	BRASS	FS03	2	1
24	MEDIUM PRESSURE SPRING	S. STEEL	FS12	1	1
25	MEDIUM PRESSURE THREADED INSERT	BRASS	FS13	1	1
26	BS011 N90 O-RING	NITRILE	BS011N90	N/A	1
27	FILTER	BRONZE	AP94	1	1
28	DIN WHEEL	BRASS	FS55D	7	1
29	DIN STEM	BRASS	FS16	3	1
30	BS111 N90 O-RING	NITRILE	BS111N90	N/A	1
31	EURO SPEC DIN WHEEL	BRASS	AP55D/G	1	1
32	EURO SPEC DIN STEM	BRASS	FS16G/O2	2	1
33	BS113 N90 O-RING	NITRILE	BS113N90	N/A	1

### 3. Service kit contents and special tools

#### 3.1 Service kit contents



**WARNING:** When replacing O-rings, next to the size, the hardness of the O-rings (declared in degrees Shore, and indicated by the suffixes N70 and N90) is ESSENTIAL for proper operation.

For example: the BS012 N90 O-ring (number 13) that acts as sealing O-ring for the 7/16" UNF high pressure port plug is deliberately chosen to be harder than the BS903 N70 O-ring (number 9) that acts as sealing O-ring for the 3/8" UNF medium pressure port plug. Simply put, O-ring 13 has a "harder" life and has to withstand a larger pressure. On the other hand, the "softer" N70 O-rings are chosen because they need to be more flexible in their specific roles (e.g. O-rings 2 and 12 that make the turret rotating action smooth).

The N70 or N90 hardness of the O-rings is deliberately selected by AP Diving.

If you choose to select your O-rings to come from another source than AP Diving, make sure you select the right type in size AND right hardness.

When servicing the FS101/FS101A 1<sup>st</sup> stage, the following parts need to be replaced:

<b>NO</b>	<b>PART NAME</b>	<b>MATERIAL</b>	<b>PART NO</b>	<b>QUANTITY</b>
2	BS019 N70 O-RING	NITRILE	BS019N70	1
4	BS806 N70 O-RING	NITRILE	BS806N70	1
5	BS006 N90 O-RING	NITRILE	BS006N90	1
9	BS903 N70 O-RING	NITRILE	BS903N70	4
12	BS024 N70 O-RING	NITRILE	BS024N70	1
13	BS012 N90 O-RING	NITRILE	BS012N90	2
17	BS010 N90 O-RING	NITRILE	BS010N90	1
18	HIGH PRESSURE VALVESEAT INSERT	PCTFE	FS20	1
21	DIAPHRAGM	NBR	FS10/1	1
26	BS011 N90 O-RING	NITRILE	BS011N90	1
27	FILTER	BRONZE	AP94	1
30	BS111 N90 O-RING	NITRILE	BS111N90	1
33	BS113 N90 O-RING	NITRILE	BS113N90	1

O-ring 30 or 33 are depending on the type of DIN wheel used.



**WARNING:** Some people still think it is possible to clean inlet filters like the bronze inlet filter (27) by ultrasonic and/or blow-through cleaning. This is NOT the case. In fact, there is a good chance that this will further block the filter. This blocking cannot be visually inspected, so the diver using such a "refurbished" filter may have to find out the hard way that the 1<sup>st</sup> stage is not delivering its supposed output due to severe resistance caused by a partially blocked filter. He will typically only find that out at depth, where the demanded flow rate of the 1<sup>st</sup> stage is the highest.....

### 3.2 Special tools

Two special tools are needed for proper servicing of the 1<sup>st</sup> stage:

- **FS TOOL 2: 7/16" holding arm.**



This tool is used for fixing the first stage in place while working on it. It is screwed into one of the two 7/16" UNF high pressure ports (14) of the main body (15).

**⚠ WARNING:** Do **NOT** use a bench vice to hold the 1<sup>st</sup> stage when working on it. The high clamping pressure exerted by a vice on the round body of the 1<sup>st</sup> stage could cause it to become distorted, damaging the 1<sup>st</sup> stage beyond repair.

ONLY use this special tool to fix the 1<sup>st</sup> stage.

You could of course choose to put one end of this special tool itself into a vice to free up both your hands for working on it, but never the 1<sup>st</sup> stage itself.

- **FS TOOL 3: 4-pin end cap removal/replacement tool.**





This tool is used for removing the open end cap (23), which seals the diaphragm in place.

Alternately, you could use a “standard” tool as depicted in the picture to remove or replace the end cap. In the latter case however you MUST make sure that:

- the tool has the correct diameter to fit around the end cap, and that its pin fits perfectly in one of the slots in the end cap;
- you can measure a torque of 25 N/m when assembling the end cap back into the main body.



**WARNING:** Do NOT use adjustable-joint pliers to remove or replace the end cap. This has the high risk of distorting the end cap, rendering it damaged beyond repair. At the very least it will cause severe scratch marks on the end cap, which will look unprofessional towards the owner of the 1<sup>st</sup> stage for whom you do the servicing.

## 4. Disassembly instructions

### 4.1 Remove all four 3/8" UNF medium port plugs



Unscrew all four 3/8" UNF medium pressure port blanking plugs (8) from the turret (10), using a 5 mm Allen key. Turn the plugs anti-clockwise.

### 4.2 Remove the two 7/16" UNF high pressure port plugs



Unscrew the two 7/16" UNF high pressure port blanking plugs (14) from the main body, using a 5 mm Allen key. Turn the plugs anti-clockwise.

### 4.3 Screw special tool FS TOOL 2 in a 7/16" UNF high pressure port



Screw the special tool FS TOOL 2 into one of the 7/16" UNF high pressure ports (14) in order to get a grip for further disassembly of the 1<sup>st</sup> stage. If needed, place the special tool itself into a bench vice to free up both hands.

**⚠ WARNING:** Do NOT use a bench vice to hold the 1<sup>st</sup> stage in.

The high pressure that can be exerted by a vice on the main body of the 1<sup>st</sup> stage could cause distortion, damaging the 1<sup>st</sup> stage beyond repair.

#### 4.4 Remove DIN wheel assembly



Using a 5 mm Allen key in the centre of the DIN stem, turn anti-clockwise and remove the DIN wheel assembly, consisting of the DIN wheel (28 or 31; depending on UK or Euro spec wheel), DIN stem (29 or 32; depending on Euro or UK spec stem), collar spacer (16), bronze filter (27) and sealing O-ring (26) from the main body.

Once disassembled, the parts should look like this: from left to right the main body with below it the 7/16" UNF and 3/8" UNF blanking plugs, sealing O-ring, bronze filter, collar spacer, DIN wheel and DIN stem. The DIN stem also holds the O-ring (30 or 33, depending on type of DIN stem used) that seals against the inside of the scuba or Oxygen cylinder valve.



#### 4.5 Unscrew the HPV housing assembly



Using a 5 mm Allen key, unscrew the HPV housing assembly (1) through the rotating turret (10) from the main body (15).

The black swivel washer (3) that sits between the HPV housing and the turret will also drop out now. It facilitates smooth rotation of the turret.

#### 4.6 Remove balance spring and HPV



Once the HPV housing assembly is removed, take out the HPV (High Pressure Valve) (7) and the balance spring (6) from the HPV housing. Just gently pull the HPV out of the housing.

#### 4.7 Remove small BS006N90 from inside of HPV housing

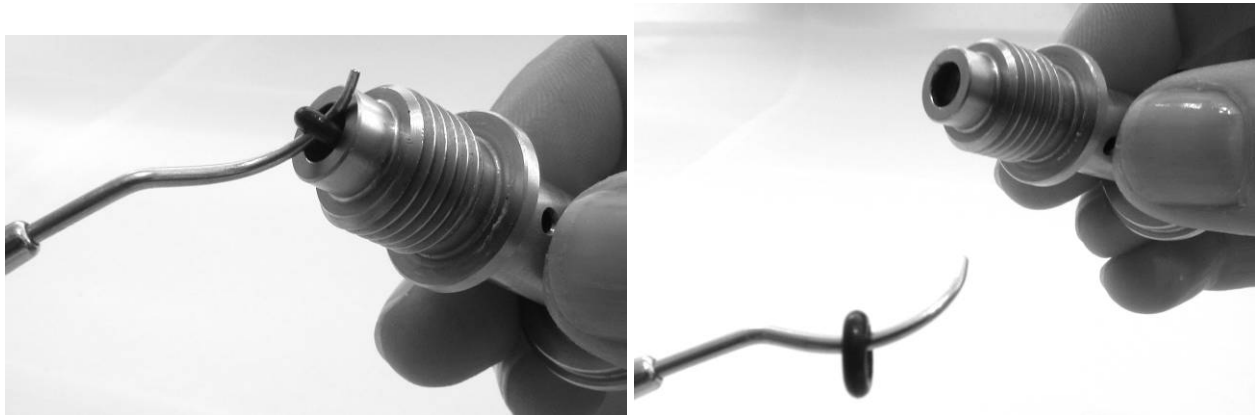

Remove the small BS006N90 (5) from the inside of the HPV housing (1). This may not be easy, as this is a quite stiff 90 degrees shore O-ring. Take your time to remove it.

- ⚠ WARNING:** If you use a sharp tool to remove the O-ring, pay attention to two things:
- it is VERY important that this O-ring is in perfect state. It is a crucial O-ring in the functioning of the 1<sup>st</sup> stage. Any damage will lead to an incorrect and unstable medium pressure. So discard it if you the slightest doubt that it got damaged in the removal process. This O-ring should be replaced with EVERY servicing.
  - make sure you do NOT scratch the inside groove of the HPV housing where this O-ring sits with your tools while trying to remove this O-ring.

#### 4.8 Remove turret, body washer and big O-ring



Now you can just lift off the turret (10) from the main body (15). Next you can remove the big sealing O-ring (12) and the big black body washer (11).

Once disassembled, the parts should look like this: from left to right the HPV housing with below it its 3 O-rings and body washer, the balance spring, the HPV, the turret with below it its swivel washer and the main body with below it its big sealing O-ring and body washer.

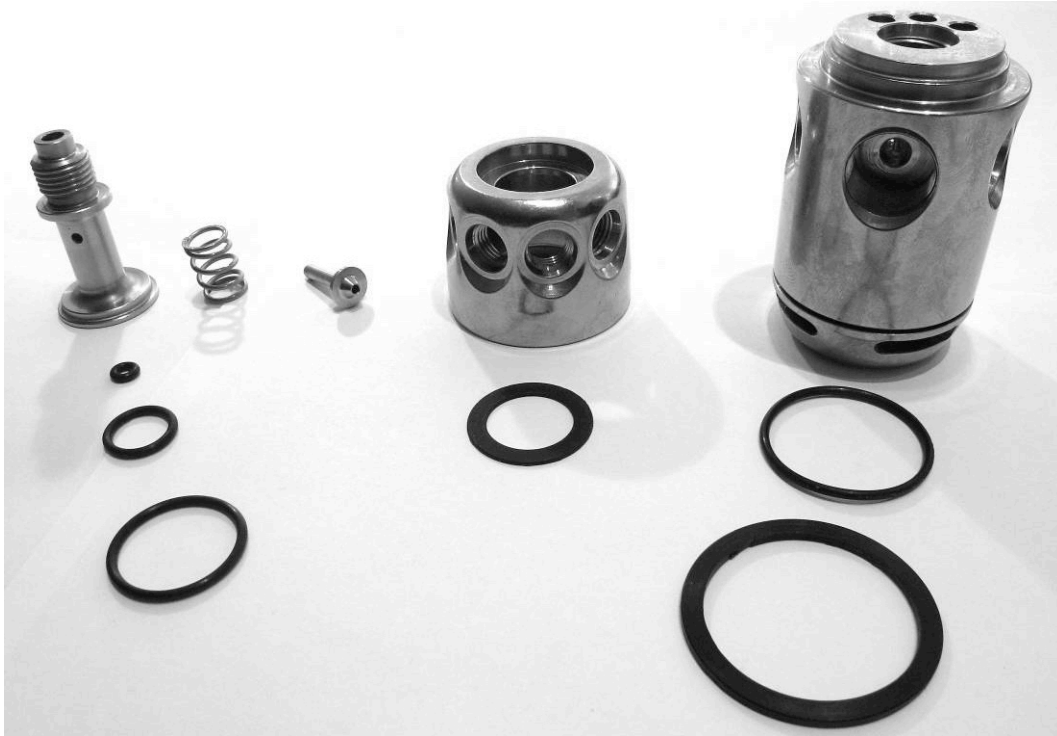

#### 4.9 Use FS TOOL 3 to unscrew the end cap

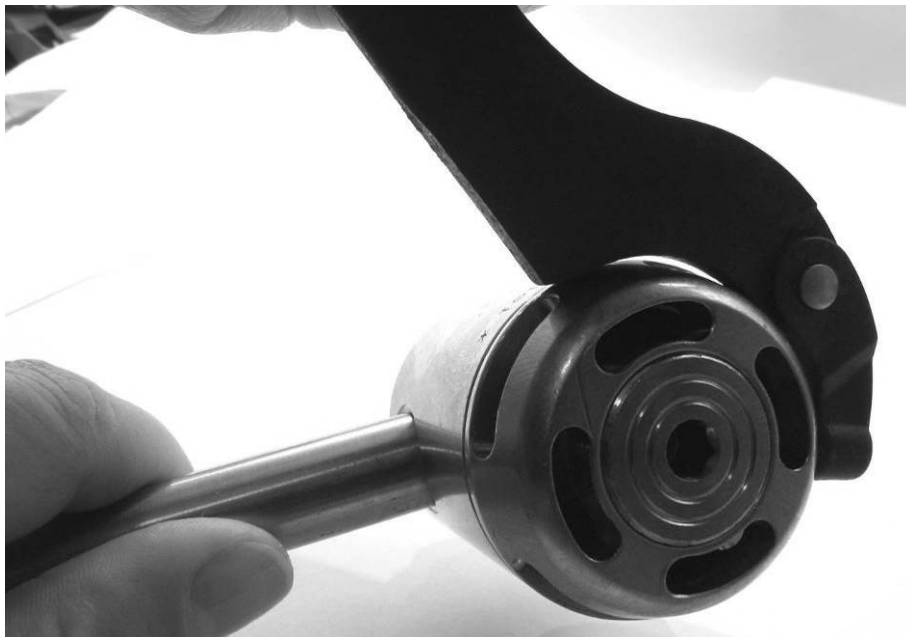

Now use special tool FS TOOL 3 or a similar adjustable tool to unscrew the open end cap (23) from the main body (15). Turn anti-clockwise.

Make sure the pin on the special tool hooks firmly into one of the grooves of the end cap.

#### 4.10 Remove medium pressure spring and balancing spring seat



Once the open end cap is removed, you will see the medium pressure spring (24) which sits on top of the acetal spring seat (22). The spring seat protects the rubber diaphragm from damage caused by the sharp end of the spring. The parts can be simply lifted out.

#### 4.11 Remove the MP threaded insert



Using a 5 mm Allen key, remove the threaded insert (25) from the open end cap (23).



Turn anti-clockwise.

#### 4.12 Remove the diaphragm



Now use a blunt instrument or very small screwdriver to remove the diaphragm (21) from the main body. Make sure you do not damage the inner wall or the groove holding the diaphragm with the instrument you use.

Damage to the diaphragm itself due to removing it is acceptable, because we will replace it with a new one anyway.

#### 4.13 Remove the load transmitter pin

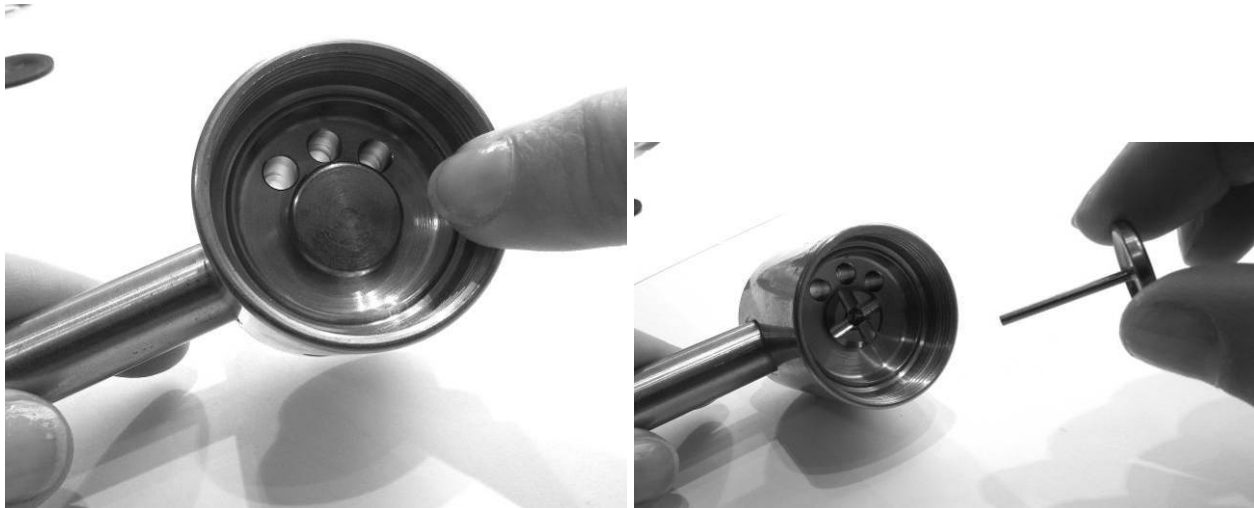

Looking into the main body, you can now see the load transmitter pin (20). If you turn the main body upside down, it will fall out by itself. No tools are needed here.

#### 4.14 Unscrew the HPV insert cap

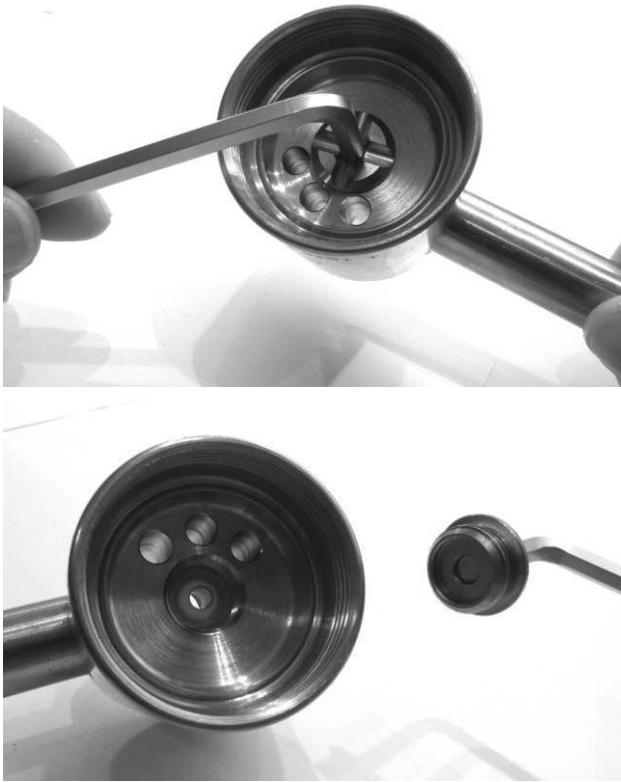

Use a 4 mm Allen key to screw the HPV insert cap (19) out of the main body (16). Once again turn anti-clockwise.

#### 4.15 Push the HPV seat insert out of the main body



From the other side (i.e. the side where you removed the turret from), gently push the HPV insert (18) out of the main body. Don't use sharp metal objects to push. We recommend you use e.g. a wooden pencil to gently push it out.

**⚠ WARNING:** It is strongly recommended to replace the HPV Seat insert with a new one each time the 1<sup>st</sup> stage is serviced. The HPV seat insert is a very essential part of the 1<sup>st</sup> stage. It seals against the incoming scuba cylinder pressure to create the medium pressure side of the valve. Any damage to the HPV seat insert could lead to a HP leak, causing the medium

pressure to build-up all the way to cylinder pressure. This could lead to either exploding medium pressure hoses and/or a ruptured diaphragm.

**⚠ WARNING:** All 1<sup>st</sup> stage regulators should be fitted with a pressure relief valve, like the AP-Valves RB17 (sold separately), or a second stage regulator. This way a too high medium pressure can escape without damaging medium pressure hoses or the diaphragm.

However, if for whatever reason you plan to re-use the HPV insert, take every precaution not to damage it while pushing it out. Use a soft surface (e.g. back-end of a wooden pencil) to gently push it out.

Once disassembled, the parts should look like this: from left to right the MP threaded insert, the open end cap, the MP spring, the balancing spring seat, the black diaphragm, the load transmitter pin, the HPV insert cap with its O-ring removed, the HPV insert and the now totally stripped main body.



**This completes the disassembly of the FS101(A) first stage.**

## 5. Clean and replace service parts

The servicing of the 1st stage inflator contains 4 “action groups”:

1. Removing and binning all parts that should be replaced. This includes all O-rings.
2. Depending on the gas content the 1st stage inflator is exposed to, keep it in oxygen service. The CGA (Compressed Gas Association), US Navy, UK’s HSE and the EIGA (European Industrial Gas Association) all recommend that breathing gasses with an oxygen content of 23.5% or higher should be treated as 100% oxygen. However, some technical training agencies still use 40% as the maximum percentage that is allowed for equipment that is not in oxygen service.  
AP Diving advises to err on the side of safety, and to use the value of 23.5% as the cutoff percentage beyond which the equipment must be in oxygen service.  
If in doubt: keep it in oxygen service, as that only takes a little bit more effort.
  - Obviously, the FS101A **MUST** be kept in oxygen service at all times, as it will be exposed to 100% oxygen at high pressure during normal use.
3. Ultrasonic-cleaning of all disassembled metal parts. This is mandatory if the 1st stage inflator is to be kept in oxygen service, but recommended in all other servicing situations.
4. Lightly grease new parts, fit them, and re-assemble the 1st stage inflator with the correct tools and the correct torques. Use oxygen-compatible grease, and avoid contaminating the metal parts after cleaning. Use the smallest amount of grease possible.

### 5.1 Service kit contents

As described in chapter 3.1, the following parts need to be replaced when servicing the 1<sup>st</sup> stage:

<u>NO</u>	<u>PART NAME</u>	<u>PURPOSE</u>	<u>PART NO</u>	<u>QUANTITY</u>
2	BS019 N70 O-RING	sits on the HPV housing and seals it against the turret	BS019N70	1
4	BS806 N70 O-RING	sits on the HPV housing and seals it against the main body	BS806N70	1
5	BS006 N90 O-RING	sits inside the HPV housing and seals it onto HPV stem	BS006N90	1
9	BS903 N70 O-RING	sits on a 3/8” UNF medium-pressure port blanking plug, or a fitted medium-pressure hose	BS903N70	4
12	BS024 N70 O-RING	sits on the main body and seals in against the turret	BS024N70	1
13	BS012 N90 O-RING	sits on a the 7/16” UNF high-pressure port blanking plug, or a fitted high-pressure hose	BS012N90	2
17	BS010 N90 O-RING	sits on the HPV insert and seals in against the main body	BS010N90	1
18	HIGH PRESSURE VALVESEAT INSERT	needs to be fitted with the above mentioned O-ring #17	FS20	1
21	DIAPHRAGM	Sits between load transmitter pin and MP spring; “conducts” the ambient water pressure to the 1 <sup>st</sup> stage	FS10/1	1

<b>NO</b>	<b>PART NAME</b>	<b>PURPOSE</b>	<b>PART NO</b>	<b>QUANTITY</b>
26	BS011 N90 O-RING	sits on the DIN stem and seals it against the main body	BS011N90	1
27	BRONZE FILTER	Keeps the inside of the 1 <sup>st</sup> stage clean of particles in supplied gas	AP94	1
30	BS111 N90 O-RING	sits in the DIN stem and seals it against the connected diving cylinder valve	BS111N90	1
33	BS113 N90 O-RING	sits in the Euro Spec DIN stem and seals it against the connected diving cylinder valve	BS113N90	1

The removal and replacement of most O-rings and parts is self-explanatory. However, one part requires special attention. See paragraph 5.5.

## 5.2 Remove BS006 N90 O-ring from the inside of HPV housing

If you haven't done this yet, see paragraph 4.7 for removal instructions.

## 5.3 Ultrasonically clean deposits from all metal parts

Clean deposits from all metal parts, like chalk and salt.

 **WARNING:** Do NOT use aggressive chemicals. They might damage the metal coating. Use an ultrasonic cleaning bath with a suitable cleaning fluid instead. A very good cleaning fluid is Biox "O2" immersion fluid. See [WWW.BIOXINT.COM](http://WWW.BIOXINT.COM) for further information and distributors.

The use of rubber gloves while re-assembling the 1st stage is highly recommended to avoid rendering the 1st stage unclean due to human touch. For the FS101A this is mandatory.

## 5.4 Replace all O-rings with new ones from the service kit

-  **WARNING:**
- Replace all O-rings: do NOT re-use old ones.
  - ONLY use original parts from APD, to ensure the O-rings:
    - o Are the exact size;
    - o Are of the correct material (especially important in a high oxygen content and overpressure environment);
    - o Are of the correct hardness (degrees Shore).
  - Make sure you use only Oxygen-compatible grease for the FS101A Oxygen version of the 1<sup>st</sup> stage.
  - Also make sure you only use Oxygen-clean and Oxygen-compatible replacement parts. All APD-supplied O-rings in the service kit are made from Nitrile and as such are Oxygen compatible. However, they still need to stay or be made Oxygen-clean.
  - Last but not least: avoid touching Oxygen-clean parts after cleaning with your bare hands. Human body sweat and grease is not Oxygen-compatible. So use (surgical) rubber gloves when re-assembling the FS101A 1<sup>st</sup> stage.

For photographic clarity no rubber gloves are worn on the photos below.

## 5.5 Replace BS006 N90 O-ring into the inside of HPV housing



Don't use tools to put a new small BS006 N90 O-ring (5) back into the inside of the HPV housing (1). Bend it, and then feed it gently vertically into the inside of the HPV housing. After that, use a soft tool (e.g. a blunt dentist pick or a wooden tooth pick) to ease the O-ring horizontally into its groove.

### 5.5 How to lightly grease O-rings

When greasing O-rings, make sure NOT to use too much grease.

Especially O<sub>2</sub> compatible grease has the potential to become stiffer over time, which may cause a hardened clot of grease to become a source for leaking.

The best way to grease O-rings is using a simple "grease bag".

A grease bag is a clean and clear plastic bag, into which you put a small amount of grease.

Optionally you can make two bags: one with O<sub>2</sub> compatible grease, and one with normal silicone grease. Make sure you label them properly to avoid mixing them up! Also put a date on it, so you know how old your grease bag is. Don't use them longer than a year.

A nice advantage of using a grease bag is that you use only a tiny amount of grease for greasing many O-rings, so there is little waste.

We recommend that you use resealable bags, e.g. the ones with a plastic zipper, typically used for airtight food storage. This allows you to zip up the bag after use, keeping the contents clean for repeated use.

The simple steps are as follows:

- Take a plastic bag and deposit a SMALL amount of grease in it.

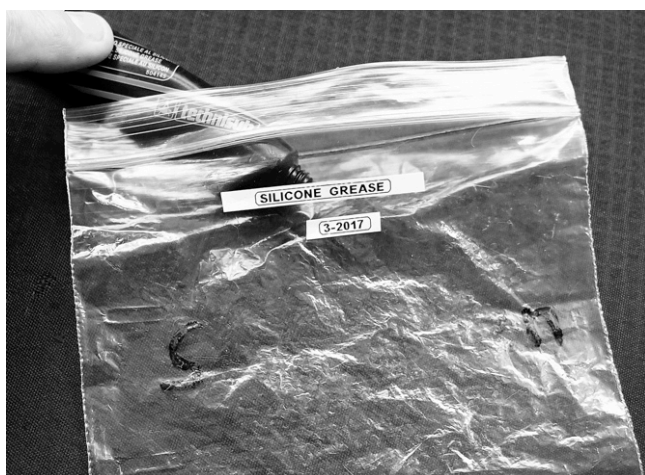

- Massage this grease all around the bag until it is evenly distributed over the inside surface area.
- Take the O-rings to be greased out of their storage container, either using gloves or using an O2-cleaned instrument like a dentist hook.

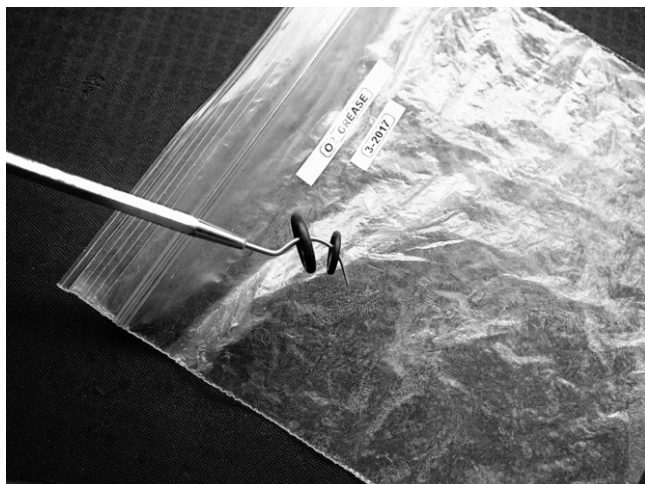

- Drop them in the grease bag, and from the outside of the bag move them around with your fingers, making sure they get in full contact with the grease.



- Open the bag, and using a clean instrument like a dentist hook, take the now properly greased O-rings out.
- Inspect them to make absolutely sure that the grease is evenly and lightly distributed on the O-rings and that there are no areas of excess grease - no globs or strands.
- Fit them where they belong on your diving equipment, still making sure not to touch them with your bare hands.



## 6. Assembly instructions

Start with the assembly of the parts on the open end cap side.  
Lay out the parts in front of you as indicated below:



### 6.1 Push the new HPV insert with its O-ring into the main body



Put the BS010 N90 (17) on the HPV insert (18) and push it into the main body (15), with the small side in front.

**⚠ WARNING:** Do NOT use tools to push the HPV insert (18) into its slot in the main body. Push the HPV insert gently and slowly in place by hand. Make sure it goes in all the way. The small side of the HPV insert should be visible from the other side, sitting flush with the surrounding metal. If your fingers are too big and you have to use a tool, use the backside of a wooden pencil with an eraser to do it (see bottom right photo on previous page). Make sure not to leave debris from the pencil or eraser behind on the HPV insert.

**⚠ WARNING:** When assembling the FS101A Oxygen version, use rubber gloves to avoid polluting the HPV while inserting, rendering it not Oxygen-clean anymore. As this part is exposed to high-pressure Oxygen and high flow rates through a small hole, it is VERY important it is and stays Oxygen-clean.

## 6.2 Screw the HPV insert cap into the main body



Screw the HPV insert cap (19) into the main body (15). Use a 4 mm Allen key. Tighten clock-wise.

## 6.3 Place the load transmitter pin into the main body

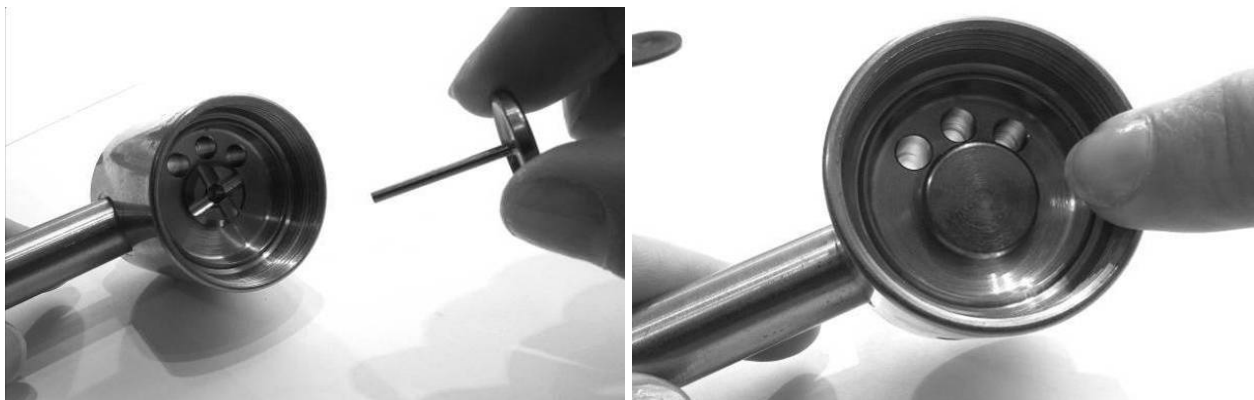

This does not require tools. Just gently drop the load transmitter pin (20) in place.

#### 6.4 Put the diaphragm into the main body



Again, you do not need tools to place the new diaphragm (21) in place on top of the load transmitter pin (20). Just bend the diaphragm between your fingers, as shown in the picture, and ease it into the groove below the thread.

You must make sure however it sits all the way down in the main body, in its own groove in the outer wall of the main body.

**⚠ WARNING:** do NOT use (sharp) tools to put the diaphragm in place. If it is “stubborn” while putting it in place, only use blunt objects (e.g. the eraser-fitted backside of a wooden pencil) to gently push it down and in place.

#### 6.5 Screw the MP threaded insert into the open end cap



Use a 5 mm Allen key. Tighten clockwise. Screw the MP threaded insert (25) in until it just sticks out on the outside of the end cap (23). This will give a good starting position for adjusting the medium pressure, as described in chapter 7.

### 6.6 Place the medium pressure spring and the balancing spring seat on top of the diaphragm



Make sure the black balancing spring (seat (22)) sits with its smooth, rounded side down in the middle of the diaphragm (21). The other, upward facing side contains a small upstand in the middle that sits in the centre of the spring (24).

### 6.7 Use FS tool 4 to screw the open end cap into the main body

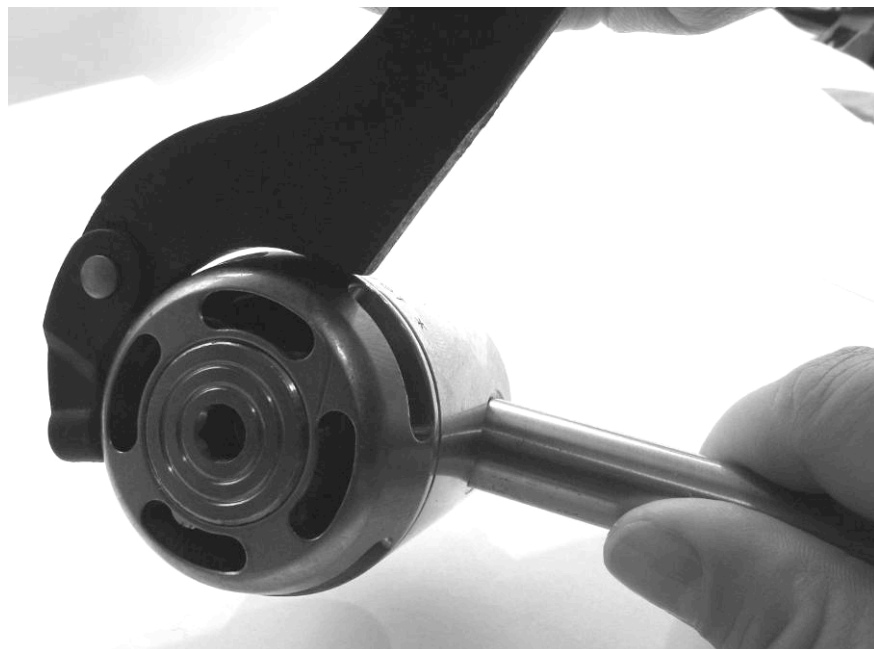

Use FS TOOL 3 or a similar tool to screw the end cap (23) into the main body. Make sure the MP spring (24) does not shift out of the centre while doing so. Make sure you do not damage the slots in the end cap. Tighten to a torque of 25N/m.

**⚠ WARNING:** Do not over- or under-tighten. Apply a torque of 25 N/m. If not enough torque is applied, the diaphragm will not seal and leak. If too much torque is applied, the diaphragm and/or the threads in the main body wall will get damaged.

The assembly of the parts on the end cap side of the 1<sup>st</sup> stage is now finished. Now we move to the other side of the 1<sup>st</sup> stage to replace the turret, the HPV and the HPV housing. Lay out the parts in front of you as indicated below:



### 6.8 Place body washer, big O-ring and turret on the main body



Place the black polypropylene body washer (11) on the main body. Next, put the big BS024N70 O-ring (12) into its groove on top of the main body (15). After that gently put the turret (10) on top of body washer and O-ring, making sure the O-ring does not shift out of place. When looking from the side, there should be no room between body washer, turret and main body.

### 6.9 Place balance spring and push HPV into HPV housing

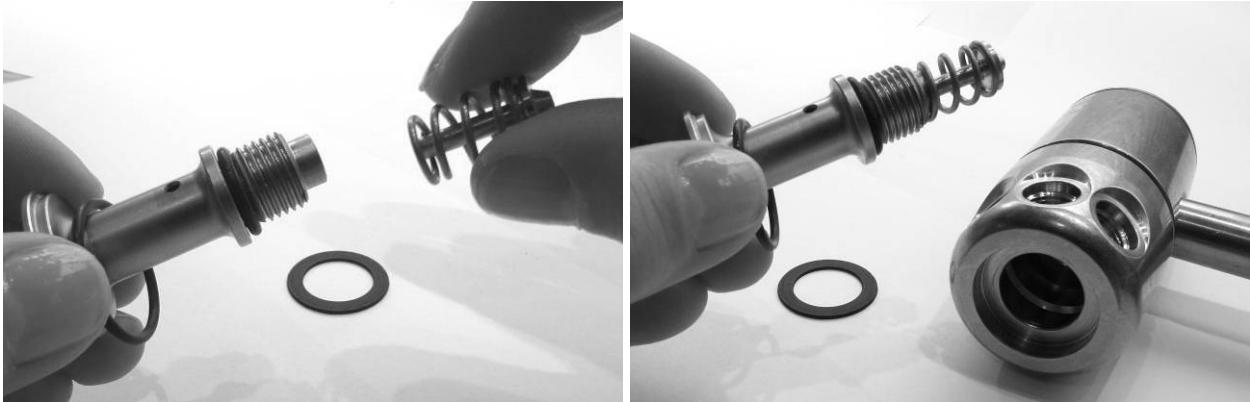

Put the stem of the HPV (7) through the balance spring (6) and push it into the HPV housing (1). You must push it through the centre of the small BS006N90 O-ring you replaced as described in paragraph 5.4. Check if the HPV can move freely by pushing it in and out gently.

### 6.10 Place swivel washer and screw the HPV housing assembly through the turret into the main body



Place the black swivel washer (3) on top of the turret (10). Fit O-rings (4) and (2) to the HPV housing. Take the complete HPV housing assembly (i.e. with balance spring (6), HPV (7) and outside O-rings (4) and (2) fitted) and gently ease it through the centre of the turret. Make sure the top O-ring (2) stays in place and does not get caught between HPV housing and turret. The whole assembly should glide smoothly into place, with the hole in the centre of the HPV sliding over the stem of the load transmitter pin (20) that is visibly sticking out of the centre of the HPV insert (18). Tighten in place with a 5 mm Allen key. Tighten clockwise.

The assembly of the parts on the turret side of the 1<sup>st</sup> stage is now finished. Now we move to the DIN wheel side of the 1<sup>st</sup> stage. Lay out the parts in front of you as indicated below:



### 6.11 Screw DIN wheel, DIN stem, collar spacer, bronze filter and sealing O-ring into the main body

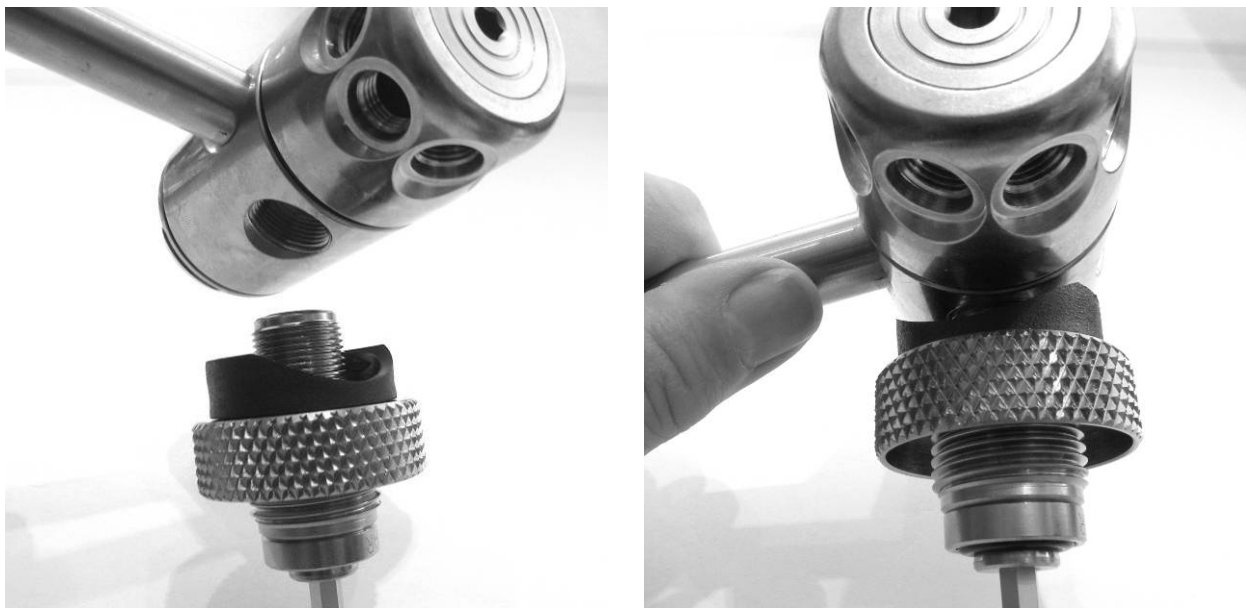



Put O-ring (30 or 33) in DIN stem. Put the DIN stem (29 or 32) through the centre of the DIN wheel (28 or 31). Put the black or green (depends on if it is the FS101 or FS101A Oxygen version) collar spacer (16) on top of it, with the curved side up.

Drop a new bronze filter (27) in, and place a new BS011N90 O-ring (26) on top of it.

The easiest way is to keep this whole assembly vertical, and gently screw it the first few threads in by hand into the main body that you hold above it with your other hand. This way the small O-ring will not fall out. Now tighten it clockwise with a 5 mm Allen key.

### 6.12 Unscrew special tool FS TOOL 2 from its 7/16" UNF high pressure port



Remove special tool FS TOOL 2 from one of the high pressure ports. Turn anti-clockwise.

### 6.13 Screw the two 7/16" UNF high pressure port plugs into the main body



Tighten clockwise. Optionally you can leave one 7/16" UNF port open to take a high pressure gauge for use during testing and adjustment.

### 6.14 Screw the 3/8" UNF medium port plugs into the turret

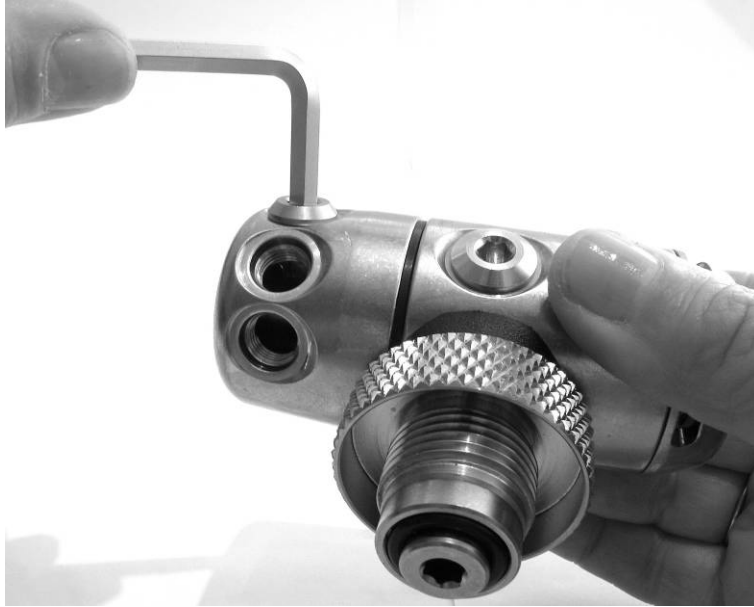

Tighten clockwise. Leave two or three 3/8" UNF ports open for testing to take:

- an overpressure release valve,
- a second stage, and
- a medium pressure gauge to inspect and adjust the intermediate pressure during testing.

### 6.15 Screw an overpressure release valve into a 3/8" UNF medium port



Tighten clockwise. Use an AP Diving original RB17 overpressure valve with a maximum relief pressure of 15 bar.



FS101 fully assembled



FS101A fully assembled

**This completes the assembly of the FS101 and FS101A first stages.**

## 7. Testing instructions

**7.1 Screw a medium pressure hose, fitted with a medium pressure gauge, into a 3/8" UNF medium port**



Tighten clockwise. Use a medium pressure gauge with a range of 0 to 15 bar.

**7.2 Optionally screw a second stage into a 3/8" UNF medium port**



Tighten clockwise. This second stage is primarily used to easily purge the hoses from gas during testing and adjusting.

### 7.3 Screw MP threaded insert into the end cap, leaving approximately 2mm of the insert showing



To make sure you do not start with an intermediate pressure that is too high, you must start with the threaded insert approximately 2mm (2 threads) above the face of the end cap. This should equate to an intermediate pressure of between 5 and 6 bar.

### 7.4 Attach assembled 1<sup>st</sup> stage onto a 50 bar air (FS101) or oxygen-compatible clean air (FS101A) source and slowly open valve



Slowly open tank the valve, while keeping the purge button of the second stage pressed. Now release purge button from second stage and listen for any leaks from second stage and/or overpressure valve. Keep an eye on the medium pressure gauge to make sure the medium pressure is not too high, e.g. outside the range of the medium pressure gauge.

## 7.5 Watch medium pressure build up



If no leaks are heard, watch the medium pressure gauge. The pressure should stay absolutely stable. If it creeps up, immediately close the tank valve and search for the root cause. Next, press the purge button from the second stage a few times. While the gas flows, the medium pressure should drop a little (typically around 0,3 bar). However, once the purge button is released again, the medium pressure should instantly return to the earlier noted stable value.

## 7.6 Close gas source, release pressure and adjust medium pressure if needed



**⚠ WARNING:** ALWAYS first close the gas source and purge the gas from the hoses before making any adjustment. All adjustments should be made on a 1<sup>st</sup> stage with no pressure on it.

Make adjustment  $\frac{1}{4}$  turn at a time, turning clockwise, screwing the threaded insert further into the end cap. Each  $\frac{1}{4}$  turn of the threaded insert should increase the intermediate pressure with roughly  $\frac{1}{3}$  bar.

Adjust the pressure to the desired value in several steps, each time repeating steps 7.2 and 7.3.

The correct intermediate pressure values for use with the APD Inspiration and Evolution closed circuit rebreathers are:

- **Oxygen side (FS101A):** **7.5 bar.** The intermediate pressure on this side should NEVER be higher than 8 bar. A higher pressure will lead to non-operation of the solenoid.
- **Diluent side (FS101):** **9.2 – 9.5 bar**, if used with the as standard fitted AP Valves AutoAir Emergency breathing valve. If another 2<sup>nd</sup> stage regulator is fitted, follow the intermediate pressure prescription of the manufacturer of that 2<sup>nd</sup> stage. However, the intermediate pressure should never be higher than 13 bar.

### **7.7 Repeat steps 7.4 through 7.6 with a high pressure (200 bar) gas source**

Repeat the steps above with a gas source (e.g. scuba cylinder) with 200 bar pressure.

The FS101(A) is a balanced design, so the previously selected intermediate pressure should stay the same, regardless of input pressure.