

Open Circuit Bailout Mouthpiece

User Instruction Manual

Contents

Copyright Notice	3
Applicable Law:.....	3
Manufacturer:.....	3
EC Type Approval & Conformity Assessment:	3
UK Type Approval & Conformity Assessment:	3
EC & UK Declaration of Conformity:.....	3
General Precautions and Warnings.....	4
Introduction	5
Risks against which the PPE is intended to protect.....	5
Limitations.....	5
Two Modes	6
The Dual Valve	7
Initial Configuration	8
Preparation and Setup.....	9
PRE-DIVE INSPECTION check list	11
Diving With Nitrox	14
Cold Water Diving.....	15
Post Dive	16
Maintenance Schedule	17
Service and Repair	18
RB110 Main Assembly	19
RB111 Dual Valve Assembly	20
RB112 Front Cover Assembly	21
Warranty Information	22

Copyright Notice

This instruction manual is copyrighted, all rights reserved. It may not, in whole or part be copied, photocopied, reproduced, translated to any electronic medium or machine-readable form without prior consent from Ambient Pressure Diving Ltd.

©2008 - 2019 Ambient Pressure Diving Ltd.
OCB Instruction Manual

Please read the instructions in this manual carefully before using the Open Circuit Bailout (OCB) mouthpiece.

Applicable Law:

All products are sold on the strict understanding that only English Law applies in cases of warranty claims and product liability, regardless of where the equipment is purchased or used. Should a claim be made then the venue for this would be in Truro, England.

If this clause is not acceptable to you or your family then return the product unused to your place of purchase for a refund.

Manufacturer:

Manufactured in the UK by Ambient Pressure Diving Ltd, Unit 2C, Water-Ma-Trout Industrial Estate, Helston, Cornwall, TR13 0LW, Telephone +44(0)1326 563834.

EC Type Approval & Conformity Assessment:

EC Type certification, module B & D of PPE regulation (EU) 2016/425, by SGS FIMKO OY, Takomotie 8, FI-00380 Helsinki, Finland. Notified Body Number 0598.



UK Type Approval & Conformity Assessment:

UKCA certification. Module B & D of PPE Regulation EU 2016/425 as amended and adopted in UK law, by SGS UK Approval Body 0120; SGS UK Ltd, Rossmore Business Park, Ellesmere Port, Cheshire CH65 3EN.



EC & UK Declaration of Conformity:

The latest manufacturers Declaration of Conformity can be found on Ambient Pressure Diving website:

<https://www.apdiving.com/en/rebreathers/resources/useful-info/>

General Precautions and Warnings

Before using this OCB mouthpiece, you must receive instruction and certification in diving rebreathers from a recognised training agency. Use of this OCB by uncertified or untrained persons is dangerous and can result in injury or death. It is very easy to configure the OCB and/or use it in an unsafe manner. Even if specific training is undertaken in its configuration and use, it is still possible to injure yourself through carelessness.

The Inspiration XPD, EVP and EVO closed circuit rebreathers' CE certification to EN14143:2013 is unaffected by the addition of this OCB mouthpiece.

This OCB mouthpiece meets the requirements of Regulation (EU) 2016/425 – CE certification when fitted to a first stage regulator conforming to EN250:2014 or EN13949:2003 and to an Ambient Pressure Diving Ltd rebreather.

Factory / Dealer prescribed service for this OCB mouthpiece is recommended at least once annually by a factory trained Ambient Pressure Diving service technician. Disassembly or repair must not be attempted by persons who are not factory trained and authorised by Ambient Pressure Diving.

Warning! Training alone is not sufficient to ensure your safety. Correct maintenance and diligent use of the equipment is essential. If sufficient forethought has not been given to equipment configuration, risk analysis, dive and emergency planning you could with one simple operation – changing from CC mode to OC mode – feed yourself gas which will not support life. DO NOT underestimate your capacity to make a mistake. Everyone makes mistakes, but making a mistake with the OCB can prove fatal.

Warning! If additional components are used in the medium pressure gas supply, for instance a gas connection system or gas switching block, it is important to realise that these may interfere with the gas flow to the OCB and degrade the breathing performance preventing the OCB from supplying sufficient gas to a hard working diver at depth. Additionally, if they interrupt the gas supply the OCB may be critically damaged on descents.

Warning! DIVING WITH HYPOXIC GASES

Know your maximum and minimum operating depths of the gas connected

Using Hypoxic Gases ON or NEAR the surface has and will KILL!!

Check and double check – don't underestimate your capacity to make a mistake!

Introduction

Thank you for choosing an Ambient Pressure Diving product. This OCB mouthpiece has been designed and manufactured with pride under a Lloyds Quality Assured BS EN ISO 9001 Quality management system.

Before you dive with your new OCB mouthpiece, it is important to read this manual in its entirety to become familiar with its features, as well as the correct procedures for setup, pre-dive inspection and post-dive maintenance.

Risks against which the PPE is intended to protect

The RB110 Open Circuit Bailout (OCB) Mouthpiece is an emergency respiratory protective device intended for diving purposes only. It must be used in conjunction with an AP Diving closed circuit rebreather, the Inspiration XPD, EVP or EVO. The whole rebreather assembly including the OCB, making it possible to supply the user with a breathable gaseous mixture under foreseeable conditions of use and taking account in particular of the maximum depth of immersion.

Limitations

Maximum certified depths: Closed Circuit = 100m. Open Circuit = 50m.

This OCB mouthpiece is not configured for buddy-breathing (multiple users).

This product is only available to trained divers with an appropriate level, Ambient Pressure Diving Ltd rebreather specific qualification from a recognised rebreather training agency.

Further information regarding use and limitations can be found in the Inspiration (XPD, EVP & EVO) Rebreather User manual.

Two Modes

The OCB Mouthpiece has 2 Modes:

1. CC. Closed Circuit rebreather diving position.
2. OC. Open Circuit diving position. This is the BAIL-OUT mode.

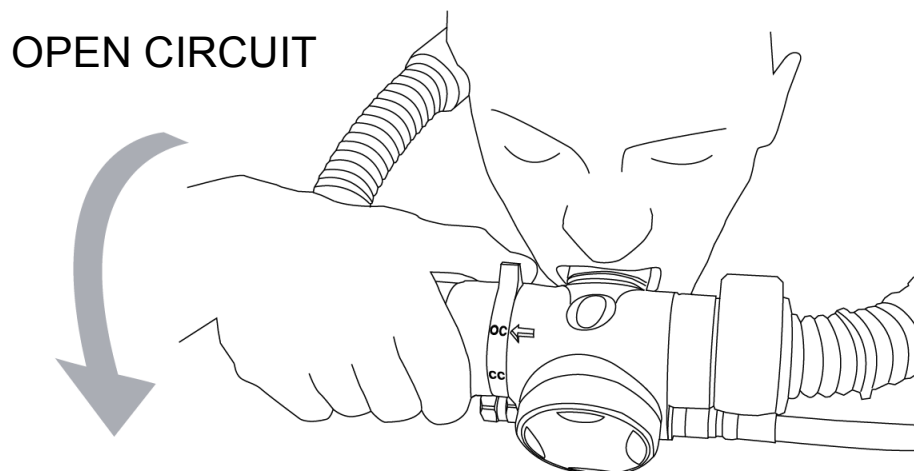
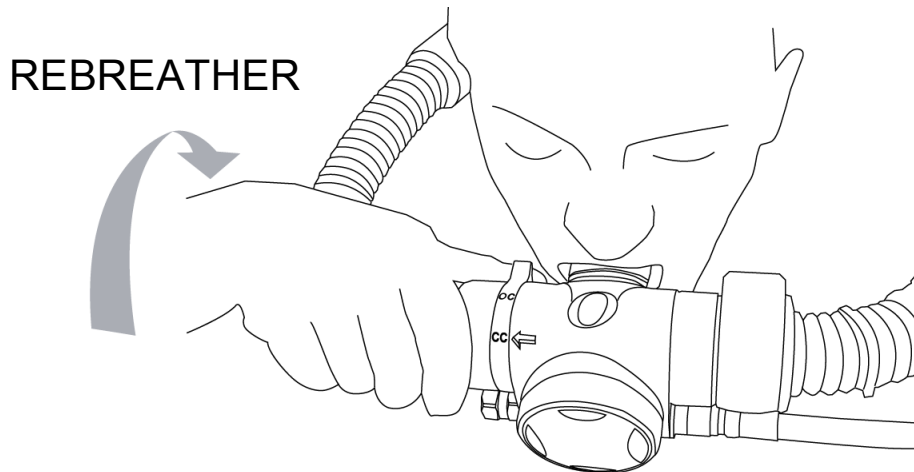

The two modes are selected by rotating the lever forwards or backwards, which in turn rotates the internal components within the main body. The Rebreather mode is activated by rotating the lever to the backward position where the lever is in line with the mouthpiece. The Open circuit mode is activated when the lever is rotated forward to the 'up' position.

The lever is best operated by the diver resting his right hand on top of the corrugated hose and placing an extended thumb between the two lugs of the lever.

The Dual Valve

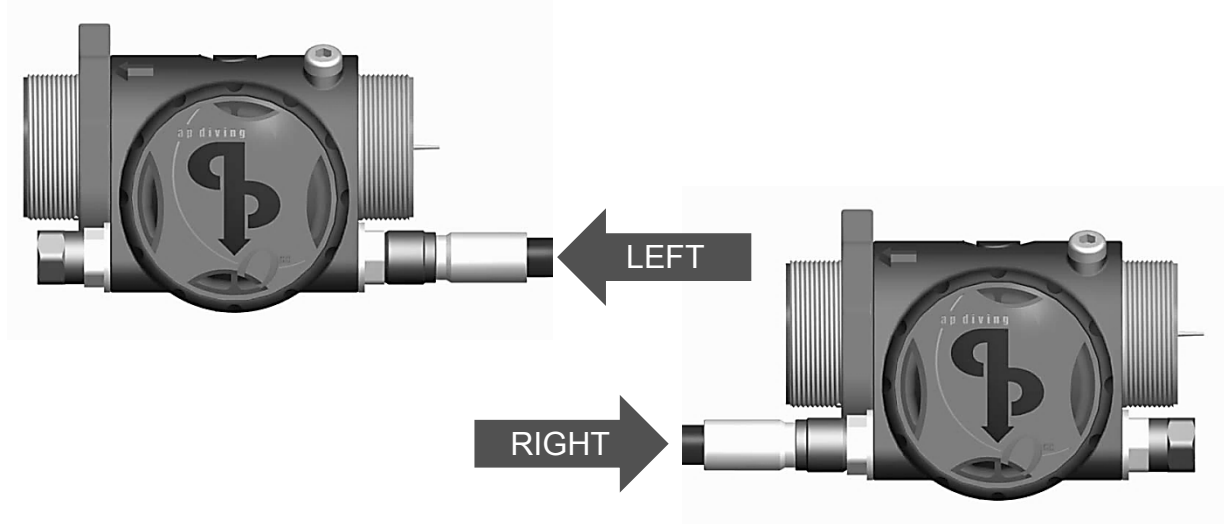

The OCB Mouthpiece utilises 'AP's new patented Dual Valve Technology. This new demand valve enables the diver to quickly and easily change the medium pressure (7 to 14 bar) supply hose routing from left hand to right hand, without the need for major disassembly, adjustment or any special tools.

The Dual Valve can be switched between left hand and right hand in simple steps:

1. Turn the gas off and purge.
2. Unscrew (anti-clockwise) the supply hose and then the 9/16" UNF blanking cap from the opposite end until the threads disengage and pull, withdrawing the plunger. (If a tool needs to be used to undo these fittings, protect the plastic moulding by preventing the Dual Valve Body from rotating by using a 17mm spanner/wrench on the adjacent hexagon nut).
3. Fully screw the plunger into the blanking cap until the threads disengage and then gently slide the plunger into the opposite side of the dual valve.
4. Screw the blanking cap on until it is tight against the shoulder, covering the thread. You should be able to do this up without tools. If resistance is met, you need to ensure the plunger is fully into the blanking cap and the threads are clean and sufficiently lubricated with silicone or oxygen compatible grease, whichever is appropriate for the gas you intend to use. While finger-tight is sufficient it is prudent to just nip it up lightly using two 17mm spanners.
5. Reconnect the supply hose. Turn the gas on slowly and test for leaks and breathing performance prior to diving.

CAUTION: When switching the valve from left to right hand hose routing, use two 17mm spanners/wrenches, one on the hexagon of the blanking cap or hose and the other on the adjacent hexagon immediately next to the valve body. Using just one spanner/wrench on the blanking cap or hose may damage the valve body.

Initial Configuration

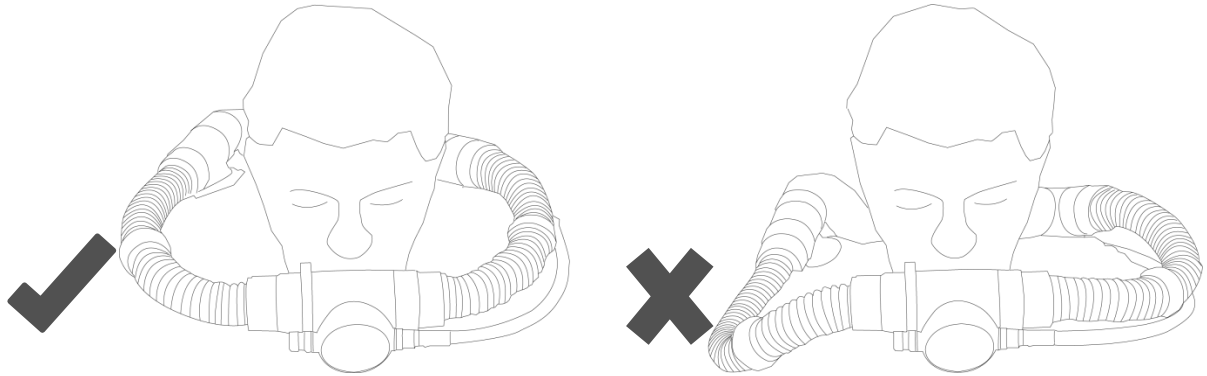

The OCB mouthpiece has been supplied with both Inhale (RB07/03) and Exhale (RB/07/04) convoluted hoses. The hose length is set at the factory. These hoses are shorter than the standard front rebreather hoses as the OCB is wider than the standard mouthpiece. However, if the hose length is too long as shown above, the hoses will need to be cut to the correct length. To reduce the length of the convoluted hoses, follow the steps below:

1. Remove the convoluted hose from the T piece.
 - a. Using the special tool (RBTOOL12), undo the locking rings and remove the split rings.
 - b. Pull the hose from the connector.
2. Cut the hose square, to the correct length using scissors.
3. Re-assemble in reverse order, ensuring the lips on the inside of the split rings hook over the flange on the connector fitting.
4. Test for leaks prior to diving.

The OCB mouthpiece has been supplied with a 1.5m Medium Pressure (7 to 14 bar) Hose, so it can be used to supply gas from a side-mounted cylinder. For supply from an onboard cylinder the hose may have to be shortened depending on the hose routing and whether you connect direct to the first stage or to the manifold.

Learn how to shorten AP Diving hoses with re-useable end fittings by following the links below:

<http://www.apdiving.com/en/rebreathers/resources/manuals/>

<http://www.apdiving.com/en/rebreathers/resources/videos/>

Preparation and Setup

- Careful consideration needs to be given to your intended use and purpose for this product as this will greatly affect the setup and configuration.
 - a. Gas volumes available, particularly at depth, need to be considered and be adequate for the intended use.
 - b. Similarly, gas types must be considered and be adequate for the intended dive. e.g. Hypoxic gases fed through a 2nd stage are very dangerous in the shallows allowing normal breathing right up until you lose consciousness.
- It is very easy to make a mistake in the setup, particularly when changing from a deep dive to a shallow dive and vice versa as the setup may be different for each dive and you can easily introduce extra dangers if you keep the same configuration.
- Training and planning are essential and it is not within the scope of this user manual to offer advice as to the best configuration for all dives but it is essential to ensure you have a respirable gas mixture available at all depths AND ensure you breathe the appropriate gas at the appropriate depth. Failure to do so may result in loss of life.
- Risk analysis is an essential part of dive planning. By using this type of valve you have a single point failure for both open circuit gas and closed circuit. It is recommended to include this fact in your risk analysis and consider having an additional 2nd stage regulator on each cylinder intended for open circuit breathing.
- Whether you choose to feed the gas from an offboard cylinder or onboard – the supply hose must be fitted to a suitable 3/8" UNF threaded outlet, designated Low Pressure (LP) or Medium Pressure (MP). The supply pressure must fall within the range 7 to 14 bar, nominally 9.5 bar. The valve is balanced and should need no adjustment for the different pressures.
- **Warning!** When in CC mode, the open circuit part of the valve is sealed, unlike a normal 2nd stage which is always at ambient pressure. Therefore it is essential to ensure the gas is switched on for the entire dive. If you leave it switched off you will catastrophically damage the diaphragm. Switching the gas on then off should also be avoided as catastrophic damage will still occur to the diaphragm, it will just occur deeper than if you hadn't turned the gas on.

Preparation and Setup Cont...

- It is recommended that you DO NOT fit an isolation valve, such as a flow-stop slide valve, between the 1st stage and the OCB for three reasons:
 1. If you do fit one and dive with it closed, the diaphragm will be catastrophically damaged as you descend.
 2. When it is closed the OCB's pressure relief valve (which normally operates at around 18 bar) cannot operate in the event of a first stage "HP seat leak".
 3. If it is closed, you have turned a "one action to go to open circuit" into a two action procedure.
- However, if you fit an isolation valve, such as a Flow-stop slider, ensure:
 - a You dive with it OPEN.
 - b You fit an additional pressure relief valve, such as the APD RB17, to the first stage.
 - c You practice it's operation often so you know for sure which way is open.
- Ensure the blanking cap has been securely screwed into the opposite side of the dual valve from the medium pressure hose. If this is not correctly located the OC demand valve will "free-flow".
- **Warning!** Check the medium pressure supply hose is connected onto the OCB before opening the cylinder valve. **If this is disconnected the flailing hose end can cause serious damage to eyes or objects nearby.**
- Check for leaks by immersing in water.
- Make sure the OCB mouthpiece is in the OPEN circuit position then depress the purge button momentarily to blow out any dust, debris or water which may have entered. Release the purge button and listen to ensure that the OCB mouthpiece does not continue to flow air after the purge button is released. If it free-flows due to the venturi, simply placing a finger over the mouthpiece opening should be sufficient to disrupt the venturi effect and allow the valve to close, the same as any normal high performance 2nd stage.

PRE-DIVE INSPECTION check list

It is essential to perform a complete pre-dive inspection of your OCB mouthpiece before every dive. NEVER dive with any diving equipment that shows signs of damage, debris, loose connections or unsatisfactory performance.

As this valve has 2 modes, OC and CC, both modes must be checked prior to diving as well as the switch-over.

1. Is it connected to the correct gas supply?
2. Is there sufficient gas volume and pressure?
3. Carefully inspect all hose fittings to ensure they are securely connected at both ends. Inspect along the length of each hose to ensure that the hoses are not blistered, cut, or otherwise damaged.
4. Visually inspect the OCB for any signs of external damage or debris.
5. Visually inspect the mouthpiece bite for damage or cuts and ensure it is securely fastened to the OCB.
6. Check the rebreather non-return valves for back leaks. Located at each end of the rotating inner are non-return valves which are keyed to prevent incorrect assembly. If disassembled, take care when inserting the inhale (blue) non-return valve into the left (inhale) side of the mouthpiece as the slot in the blue valve holder **MUST** align with the ridge in the mouthpiece tube. If it is inserted out of line, the blue holder can be damaged irreparably increasing the inhaled CO₂. **It is essential to check the direction of gas flow and check the proper operation of the non-return valves prior to each dive.** The valves can leak due to debris left over from cleaning, due to faulty assembly, worn components or due to being frozen open (in freezing conditions). This check can be easily carried out by disconnecting the hose connectors from the T piece and gently blowing and sucking against the connectors. The direction of gas flow for the Ambient Pressure Diving rebreathers is clockwise when looking down on the unit. i.e. you exhale over your right shoulder. The correct flow direction is indicated by the arrow on the mouthpiece moulding when the arrow is on top.

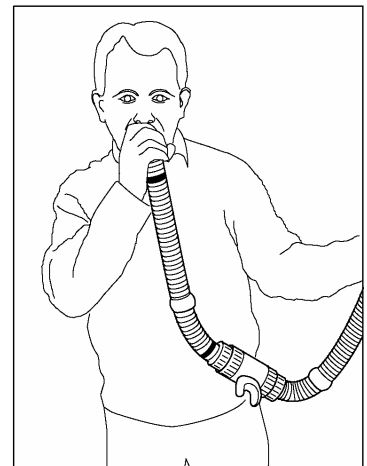

PRE-DIVE INSPECTION check list Cont...

Therefore, when blowing into the right hand side hose connector the non-return valve will close and it should open when air is sucked from the connector. The non-return valve on the other end of the mouthpiece inner tube should close when air is sucked from the left hand connector and open when air is blown into the connector.

After reassembling the hose to the unit check for correct operation by alternately squeezing the inhale and exhale tubes as you inhale and exhale. Gas must come from the left and go out to the right. You must not be able to inhale gas from the exhale tube and exhale gas into the inhale tube.

NOTE: If reverse gas flow is required, i.e. for fitting to another make of rebreather, the end of the keyway should be cut out of the bore so that it doesn't interfere with the non-return valve holder.

7. Ensure the blanking cap has been securely screwed into the opposite side of the dual valve from the medium pressure hose. If this is not correctly located the OC demand valve will "free-flow".
8. Check for a smooth and positive switching operation between OPEN and CLOSED modes.
9. Check the diaphragm and open circuit exhale valve for back leaks by blocking the MP inlet with your thumb and inhaling. If the valve is in the open circuit position and you can draw air in, there is a problem with the OCB which must be addressed before diving. If you block the gas supply by simply closing the supply valve you are likely to draw air in passed the 1st stage to tank valve seal so it is unlikely that a proper negative pressure check can be achieved.
10. In the CLOSED circuit position, carry out a positive and negative pressure test of the breathing loop.
11. **WARNING!** Re-check the medium pressure supply hose is securely connected onto the OCB before opening the cylinder valve. **If this is disconnected or comes loose the flailing hose end can cause serious damage to eyes or objects nearby.**

PRE-DIVE INSPECTION check list Cont...

12. Check to ensure that the submersible pressure gauge is displaying zero pressure. If the system is depressurised and the gauge indicates a pressure, the gauge must be replaced before diving.
13. SLOWLY open the cylinder valve to pressurise the OCB mouthpiece. Continue to open the valve anti-clock-wise until the valve is fully open. It is essential to dive with the supply valve open. By closing the supply valve the OC portion of the OCB cannot equalise as you descend and the diaphragm will eventually implode. Also, you introduce the need for another action in the event of an emergency defeating the idea of the OCB from which you can breathe open circuit gas by one simple action.
14. Check the submersible pressure gauge is displaying an accurate measurement of the gas pressure inside the cylinder (ON and OFF board).
15. Make sure the OCB mouthpiece is in the OPEN circuit position then depress the purge button momentarily to blow out any dust, debris or water which may have entered the OCB mouthpiece. Release the purge button and listen to ensure that the OCB mouthpiece does not continue to flow any air after the purge button is released. A venturi induced free-flow may be stopped by simply placing a finger over the mouthpiece orifice. (if this occurs underwater, for instance when you remove it from your mouth and allow the mouthpiece to point upwards simply rotate the OCB so the mouthpiece is pointing downwards to stop the venturi, as you would with a normal second stage).
16. Still in the Open Circuit position inhale slowly and deeply from the OCB mouthpiece several times. The OCB mouthpiece must deliver enough gas for you to breathe easily without noticeable resistance.
17. Is the gas turned on?
18. Ensure you can see the Head Up Display. The OCB is wider than the standard mouthpiece, so the HUD may need to slide across in it's holder towards the centre.

Diving With Nitrox

Your OCB mouthpiece has been prepared for use with 100% oxygen. This is possible because each OCB is built to a high standard of cleanliness using oxygen compatible components and lubricants. In addition, each OCB mouthpiece has passed stringent adiabatic compression testing to ensure its safety and compatibility with increased percentages of oxygen.

If it is your intention to use your new OCB mouthpiece with oxygen content higher than 21%, it is imperative that you maintain the internal cleanliness of the OCB mouthpiece and EN250, EN13949 certified First Stage. If it is your intent to use the OCB mouthpiece interchangeably with breathing air, the breathing air should be oxygen-compatible or “hyper filtered” with condensed hydrocarbons not exceeding 0.01 mg/m³. Standard compressed breathing air, often referred to as Grade E, does not necessarily meet this criterion.

Warning! At all times remember the maximum / minimum operating depth and exposure time for the O₂ content of the breathing gas you are using.

Warning! When using gases with a high Oxygen content take EXTRA care to open cylinder valves VERY slowly.

Warning! If the OCB mouthpiece is ever used with an oil contaminated gas supply the complete valve will need a complete overhaul and re-clean before being used with oxygen or oxygen enriched gases.

Cold Water Diving

The C.E.N. standards define cold water as 10°C or lower. In such conditions, particularly in fresh water, which has a higher freezing point and more severe thermoclines, there is a risk of freeze-up resulting in free flow and a rapid loss of gas.

It is possible for icing or freeze-up to occur in the mouthpiece, even though the OCB has been specially designed for cold water use. The following measures will reduce the risk of freeze:

1. Request verification from your dive store that the air in your cylinder(s) is dry. It should have a dew point below -54°C. Excess water vapour can freeze, causing a freeflow condition, or blocking the flow of air entirely.
2. Protect your OCB mouthpiece from any contact with water until the moment that you are ready to begin your dive.
3. Protect your equipment from cold temperatures before the dive. Keep your OCB mouthpiece in a warm dry place.
4. Avoid breathing through the OCB mouthpiece or pressing the purge button in very cold air before entering the water.
5. Avoid removing the OCB mouthpiece from your mouth during the dive. This will prevent cold water from entering the OCB mouthpiece.
6. Try to avoid heavy exertion during the dive in order to minimise the volume of air flowing through the OCB mouthpiece. Avoid discharges of air on the surface. Do not continually press the purge button.

Post Dive

It is important to provide the proper preventative maintenance in order to ensure the best possible performance and maximum life of your OCB mouthpiece. The following maintenance procedures should be performed routinely after each use to ensure that the OCB mouthpiece is cleaned, inspected, and prepared for the next use or for storage:

1. As soon as possible after diving, the OCB mouthpiece should be rinsed thoroughly with fresh water while it is attached to a cylinder and pressurised with air. If disconnected ensure water does not enter.
2. However, rinsing alone will not sufficiently clean the OCB mouthpiece. To clean the OCB mouthpiece as thoroughly as possible, it is necessary to soak it in warm fresh tap water for at least one hour.
3. After rinsing be sure to check the Closed Circuit non-return valves are not back-leaking.
4. Wipe the OCB mouthpiece as dry as possible and hang in the OPEN mode to ensure all remaining moisture drains from the mouthpiece.
5. Store the OCB mouthpiece in a clean, dry place. Do not store the OCB mouthpiece where it may be exposed to: extreme heat, ozone (electric motor), chlorine or ultra violet rays.
6. Do not use any type of solvent or petroleum based substances to clean or lubricate any part of the OCB mouthpiece. Do not expose any part to aerosol spray.

Maintenance Schedule

To keep the OCB Mouthpiece running smoothly and efficiently it is imperative to thoroughly wash and dry the unit after each dive as described on page 18. The OCB mouthpiece also requires periodic dis-assembly and re-greasing of O rings 1,2 and 3, shown in the diagram below. The time-spans between dis-assembly and re-greasing will vary depending on usage patterns. It is best to clean the components in fresh water and re-grease the O rings whenever any excessive stiffness or stickiness is felt, when rotating between the two modes.

Dis-Assembly and Re-Greasing Instructions:

1. Remove all hoses. The two convoluted hose nuts can be unscrewed once the stainless steel locking screws have been removed.
2. Remove the location screw using a small screwdriver.
3. Withdraw the inner component from the outer, carefully.
4. Remove the 3 O rings and clean all components in fresh water.

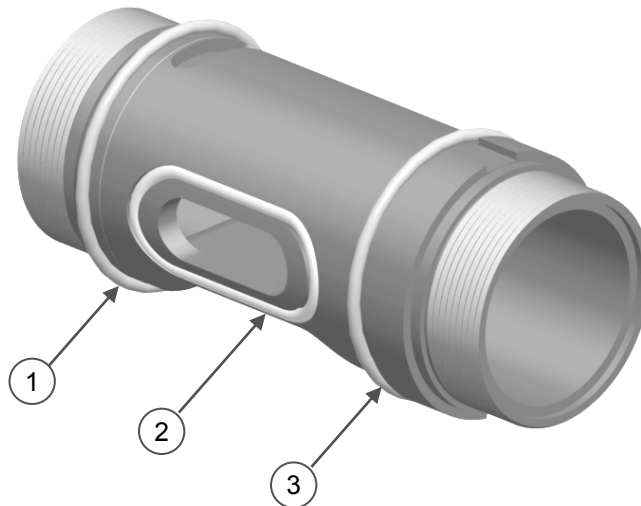

5. Apply a smear of fresh Silicon Grease to the 3 O rings and re-assemble. Applying excessive grease can cause problems, especially when diving in cold water.
6. CAREFULLY re-insert the inner into the outer, taking care not to scratch the bore or dislodge any of the O rings.
7. Align the groove in the inner component with the hole for the location screw and re-insert the location screw into the outer, taking care with the O ring and ensuring you do not over-tighten.
8. Re-connect all hoses. Rotate the convoluted hose nuts so the stainless steel locking screws can go in the same holes they came from.

Service and Repair

Dealer Service & Repair

1. It cannot be assumed that any diving equipment is in good working order on the basis that it has received little use since it was last serviced. Remember that prolonged or improper storage can still result in internal corrosion and/or deterioration of O-ring seals.
2. We recommend you obtain factory prescribed service for your OCB mouthpiece at least once a year from an authorised dealer, regardless of the amount of use it has received. Your OCB mouthpiece may require this service more frequently, depending on the amount of use it receives and the environmental conditions in which it is used.
3. If the OCB mouthpiece is used for rental or training purposes, it will require complete overhaul and factory prescribed service every three to six months or 50 hours continual use. Chlorinated swimming pool water is an especially damaging environment for diving equipment due to the high levels of chlorine and pH balancing chemicals which cause certain components to rapidly deteriorate.
4. If water is allowed in the Medium Pressure gas inlet then more frequent servicing will be required.

We recommend obtaining service for your Open Circuit Bailout mouthpiece at least once a year, from the factory or an authorised dealer. Your personal safety and the mechanical integrity of your OCB mouthpiece may depend on it.

Factory Service and Repair

Returning Your OCB mouthpiece for Service

Whenever your OCB mouthpiece requires annual service take it or send it, postage paid, to the factory or an authorised Ambient Pressure Diving dealer. For help in finding a dealer in your area, please contact your local distributor. Your distributor details can be found on our website www.apdiving.com or by contacting the factory.

RB110 Main Assembly

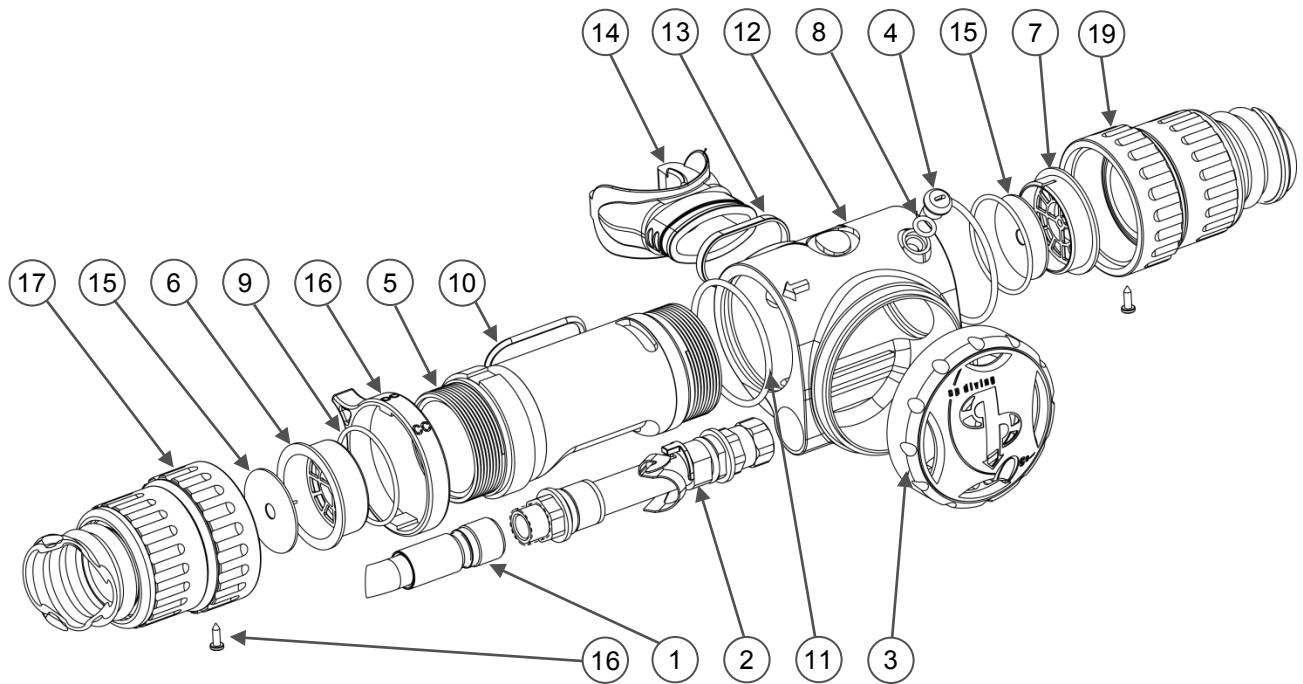

No.	Part No.	Description	Qty
1	AP300	Inflator Hose Assembly	1
2	RB111	Dual Valve Assembly	1
3	RB112	Front Cover Assembly	1
4	RB114/1	Location Screw	1
5	RB116	Inner	1
6	RB02/04	One Way Valve Holder RH	1
7	RB02/03	One Way Valve Holder LH	1
8	BS.010	O Ring Seal	1
9	BS.029	One Way Holder Seal	2
10	BS.125	Mouthpiece Seal	1
11	BS.48X2.5	Inner / Outer Seal	2
12	RB115	Main Outer	1
13	AP21	Ty-rap	1
14	AP16	Mouthpiece	1
15	RB02/05	One Way Valve	2
16	RB116/1	Inner Lever	1
17	RB07/03	Exhale Hose Assembly	1
18	SC102	Hose Collar Screw	2
19	RB07/04	Inhale Hose Assembly	1

RB111 Dual Valve Assembly

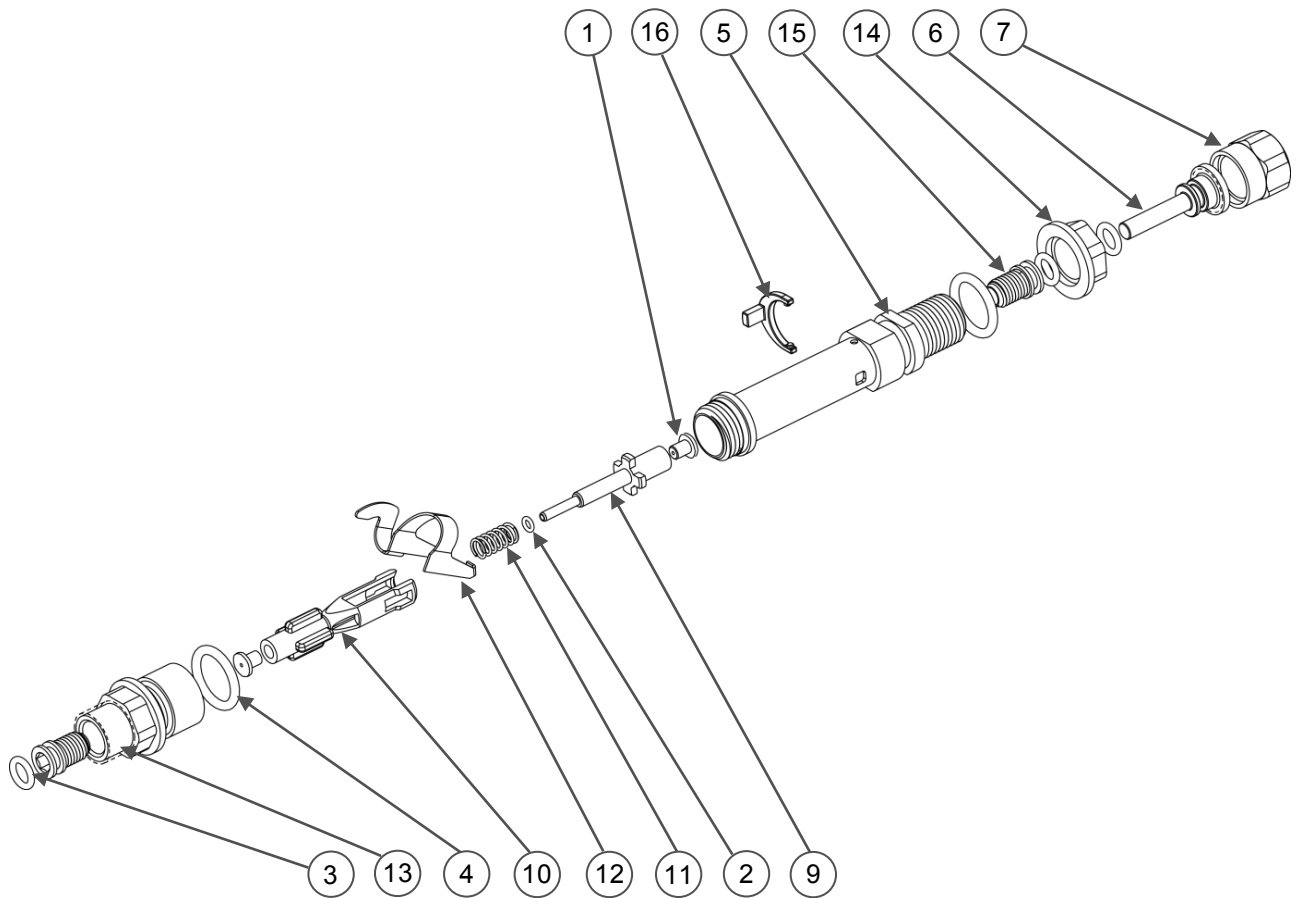

No.	Part No.	Description	Qty
1	APV100/23	Silicone Valve Seat	2
2	BS.2.6x1	O Ring	1
3	BS.010	O Ring	3
4	BS.14.5x2.5	O Ring	2
5	RB111/1	Valve Body	1
6	RB111/10	Plunger	1
7	RB111/11	9/16" Blanking Plug	1
8	RB111/12	Lever Foot Insert	1
9	RB111/2	Counter Balance Piston	1
10	RB111/3	Counter Balance Cylinder	1
11	RB111/5	Dual Valve Spring	1
12	RB111/6	Lever	1
13	RB111/7	Valve Body End	1
14	RB111/8	Valve Locking Nut	1
15	RB111/9	Valve Seat Adjuster	2

RB112 Front Cover Assembly

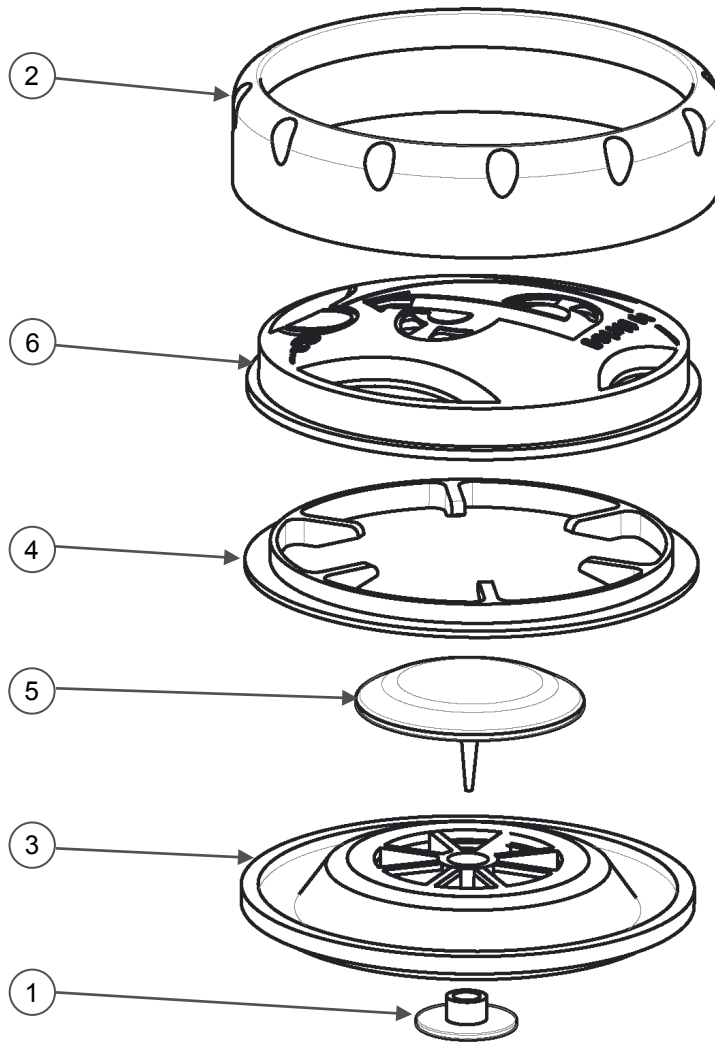

No.	Part No.	Description	Qty
1	RB112/6	Diaphragm Lever Pad	1
2	RB112/1	Locking Ring	1
3	RB112/5	Diaphragm	1
4	RB112/3	Skid Disk	1
5	RB112/4	Exhaust Diaphragm	1
6	Rb112/2	Rubber Cover	1

Warranty Information

The OCB Mouthpiece is warranted for the first owner for 24 months from the date of purchase.

Conditions:

All warranty work must be authorised by Ambient Pressure Diving. Before returning the apparatus for any reason, please contact the factory for advice. If it is deemed that a factory repair is required the product should be returned, postage and insurance paid, with a copy of the purchase receipt, directly to the factory or the Country distributor (see website www.apdiving.com).

1. This warranty does not apply to units subjected to misuse, abuse, neglect, modification, or unauthorised service.
2. This warranty is not transferable.
3. This warranty does not cover normal wear. Factory prescribed service by an authorised dealer is recommended at least once annually.
4. This warranty does not extend to damages caused by improper use, improper maintenance, neglect, unauthorised repairs, modifications, accidents, fire, or casualty.
5. Cosmetic damage such as scratches, dents and nicks are not covered by this warranty.
6. This warranty does not extend to equipment used for rental, commercial or military purposes.

Your statutory rights are unaffected.

Warning: It is dangerous for untrained and uncertified persons to use the equipment covered by this warranty. Therefore, use of this equipment by an untrained person renders any and all warranties null and void.

Designed and Manufactured in the UK by:



AP Diving
Water-ma-Trout Industrial Estate,
Helston, Cornwall. TR13 0LW.

Telephone: +44 (0)1326 563834

For spares and accessories visit:

www.apdiving.com